



MANUAL: HYDRANT MASTER

REMOTE CONTROL HYDRANT SLIDE VALVE

INSTRUCTIONS FOR SAFE OPERATION AND MAINTENANCE

WARNING

Understand manual before use. Operation of this device without understanding the manual and receiving proper training is a misuse of this equipment. Obtain safety information at www.tft.com/serial-number

NOTICE

This instruction manual is intended to familiarize firefighters and maintenance personnel with the operation, servicing, and safety procedures associated with the Hydrant Master.

NOTICE

This manual should be kept available to all operating and maintenance personnel.

OPERATING RANGE:
Pressure Max 300 PSI
Pressure Min 10 PSI

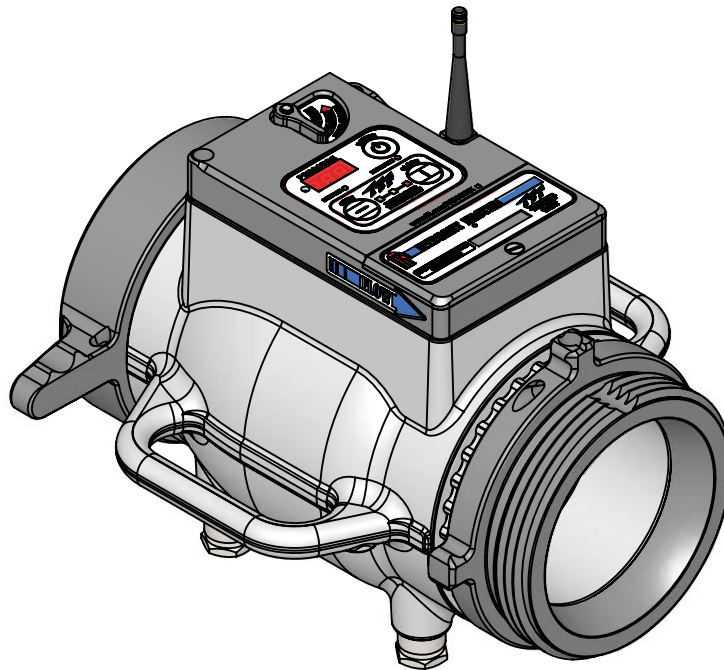

TASK FORCE TIPS, INC.
MADE IN USA • www.tft.com

3701 Innovation Way, Valparaiso, IN 46383-9327 USA
800-348-2686 • 219- 462-6161 • Fax 219-464-7155

Table Of Contents

- 1.0 MEANING OF SAFETY SIGNAL WORDS
- 2.0 SAFETY
- 3.0 GENERAL INFORMATION
 - 3.1 VALVE SPECIFICATIONS
 - 3.2 WIRELESS HANDHELD REMOTE CONTROL SPECIFICATIONS
 - 3.3 CORROSION
 - 3.4 USE WITH SALT WATER
 - 3.5 LOW TEMPERATURE USE
 - 3.6 FEATURE IDENTIFICATION
 - 3.7 DISPLAY & CONTROL PANEL
 - 3.7.1 PRESSURE DISPLAY
 - 3.7.2 PHOTO SENSOR
 - 3.7.3 BUTTONS
 - 3.7.4 LEDS
 - 3.7.5 VALVE POSITION INDICATORS
 - 3.8 POWER SAVE MODE
 - 3.9 VALVE POSITION INDICATOR & MECHANICAL OVERRIDE
 - 3.10 FLOW CONTROL FEATURE
 - 3.11 AUTOMATIC DRAIN
 - 3.12 AIR FLUSH PORT
- 4.0 INSTALLATION & CONFIGURATION
 - 4.1 VALVE STORAGE BRACKET INSTALLATION
 - 4.2 HANDHELD REMOTE CONTROL STORAGE BRACKET INSTALLATION
 - 4.3 SECONDARY HANDHELD REMOTE CONTROL
- 5.0 USE
 - 5.1 PREPARING VALVE FOR USE
 - 5.2 OPERATOR INSTRUCTIONS & VALVE FUNCTION
 - 5.3 PRESSURE LOSS
- 6.0 MAINTENANCE
 - 6.1 CHANGING BATTERIES
 - 6.2 TROUBLESHOOTING
- 7.0 EXPLODED VIEW
 - 7.1 PARTS LIST
 - 7.2 INLET COMPONENTS
 - 7.3 OUTLET COMPONENTS
- 8.0 WARRANTY



PERSONAL RESPONSIBILITY CODE

The member companies of FEMSA that provide emergency response equipment and services want responders to know and understand the following:

1. Firefighting and Emergency Response are inherently dangerous activities requiring proper training in their hazards and the use of extreme caution at all times.
2. It is your responsibility to read and understand any user's instructions, including purpose and limitations, provided with any piece of equipment you may be called upon to use.
3. It is your responsibility to know that you have been properly trained in Firefighting and/or Emergency Response and in the use, precautions, and care of any equipment you may be called upon to use.
4. It is your responsibility to be in proper physical condition and to maintain the personal skill level required to operate any equipment you may be called upon to use.
5. It is your responsibility to know that your equipment is in operable condition and has been maintained in accordance with the manufacturer's instructions.
6. Failure to follow these guidelines may result in death, burns or other severe injury.



Fire and Emergency Manufacturers and Service Association
P.O. Box 147, Lynnfield, MA 01940 • www.FEMSA.org

1.0 MEANING OF SAFETY SIGNAL WORDS

A safety related message is identified by a safety alert symbol and a signal word to indicate the level of risk involved with a particular hazard. Per ANSI standard Z535.6-2006, the definitions of the four signal words are as follows:



DANGER indicates a hazardous situation which, if not avoided, will result in death or serious injury.



WARNING indicates a hazardous situation which, if not avoided, could result in death or serious injury.



CAUTION indicates a potentially hazardous situation which, if not avoided, may result in minor or moderate injury.



NOTICE is used to address practices not related to personal injury.

2.0 SAFETY



Injury or death can result from burst hoses and fittings. Risk can be minimized by the proper care and use of hose and appliances per NFPA 1962. The relief valve must be set to an appropriate pressure based on the type of hose and equipment you are using.



Injury or death may occur by attempting to use a damaged valve. Per NFPA 1962, the device shall be inspected and tested at least quarterly. Before use, inspect for damage resulting from:

- Failure to drain valve followed by exposure to freezing conditions
- Exposure to temperatures in excess of 160 degrees F
- Missing parts, physical abuse



This equipment is intended for use by trained personnel for firefighting. Its use for other purposes may involve hazards not addressed by this manual. Seek appropriate guidance and training to reduce risk of injury.



Kinks in supply hose may reduce water flow and cause injury or death to persons dependant on water flow. Avoid tight bends to minimize risk of hoseline kinks.



The Hydrant Master is not rated for use in explosive atmospheres.



The valve may be damaged if frozen while containing significant amounts of water. Such damage may be difficult to detect visually and can lead to possible injury or death. Any time the valve is subject to possible damage due to freezing, it must be hydrostatically tested by qualified personnel before being considered safe for use.



Minimum operating pressure 5 psi (0.3 bar). Inadequate water pressure will prevent valve from opening and may result in a lack of water flow and cause injury or death to persons dependant on water flow. Ensure there is adequate water pressure supplied to inlet of valve.



Maximum operating pressure is 300 psi (20 bar). Exceeding 300 psi (20 bar) on either side of the valve may damage valve and could cause injury.



Valve must be properly connected. Mismatched or damaged connectors may cause leaking or uncoupling under pressure and could cause injury.



Any alterations to the valve and its markings could diminish safety and constitutes a misuse of this product.

3.0 GENERAL INFORMATION

The Hydrant Master is a lightweight, low friction-loss hydrant valve that can be used in many water distribution applications. The valve is powered by (4) AA batteries, pressure activated, and equipped with a power-save mode. A handheld controller with pressure display and valve position feedback controls the valve up to 1200 feet (366 m) away. Both the valve and handheld are equipped with backlighting for use in low-light situations. The valve opens and closes with a sliding plug which is compliant with NFPA 1965 slow close requirements. The valve's position is controlled by operating a control valve which can be moved manually, operated electronically from push buttons on the valve, or by wireless remote control.

3.1 VALVE SPECIFICATIONS

Main LDH Waterway size (at valve seat): 4.5" (114 mm)

Meets NFPA 1965 3.3.11.3 Slow-Operating Valve requirement.

Minimum Operating Pressure: 5 psi (0.7 Bar) NOT FOR SUCTION USE.

Maximum Operating Pressure: 300 psi (20 bar)

Hydrostatic Proof Test Pressure: 900 psi (62 bar)

Temperature Rating*: -25°F to 135°F (-32°C to 57°C)

Batteries: 4 AA batteries, Lithium recommended

Expected valve battery life: 140 hours lithium, 100 hours alkaline

*For temperatures below 32°F (0°C), valves must be drained after use to avoid damage. See section 3.5 LOW TEMPERATURE USE

Environmental Rating: All components designed to meet minimum rating of NEMA 4 (IP65).

3.2 WIRELESS HANDHELD REMOTE CONTROL SPECIFICATIONS

Batteries: 4 AA batteries, Lithium recommended

Expected handheld remote control battery life: 55 hours lithium, 40 hours alkaline

Specifications	900 MHz	2.4 GHz
Transmitting Power	100mW	10mW
Operating Range (Line of sight)	1200 ft (366m)	600 ft (183m)
Operating Frequency	900 MHz (902-928 MHz)	2.4GHz (2.410-2.470 GHz)

Agency Approvals	900 MHz	2.4 GHz
FCC	MCQ-XBEEEXSC	OUR-XBEEPRO
Industry Canada (IC)	1846A-XBEEEXSC	4214A XBEEPRO
Europe N/A ETSI	N/A	ETSI

Finished Good # AU-RU-900 Contains FCC ID: MCQ-XBEEEXSC The enclosed device complies with Part 15 of the FCC Rules. Operation is subject to the following two conditions: (i.) this device may not cause harmful interference and (ii.) this device must accept any interference received, including interference that may cause undesired operation.

Finished Good # AU-RF-2400 Contains FCC ID: OUR-XBEEPRO The enclosed device complies with Part 15 of the FCC Rules. Operation is subject to the following two conditions: (i.) this device may not cause harmful interference and (ii.) this device must accept any interference received, including interference that may cause undesired operation.

3.3 CORROSION

Most hose couplings are attached using polymer bearing rings which provide electrical insulation to help galvanic corrosion. The parts are hard anodized, and powder coated to help prevent corrosion. The effects of corrosion can be minimized by good maintenance practice. See section 3.12 AIR FLUSH PORT & 6.0 MAINTENANCE.

3.4 USE WITH SALT WATER

Use with salt water is permissible provided valve is thoroughly cleaned with fresh water after each use. The service life of the valve may be shortened due to the effects of corrosion and is not covered under warranty.

3.5 LOW TEMPERATURE USE

The valve is designed with self-draining waterways. In extreme freezing conditions, extra precautions should be taken to ensure control waterways remain free from ice. Residual water should be cleared from the valve after each use. See section 3.12 AIR FLUSH PORT.

3.6 FEATURE IDENTIFICATION

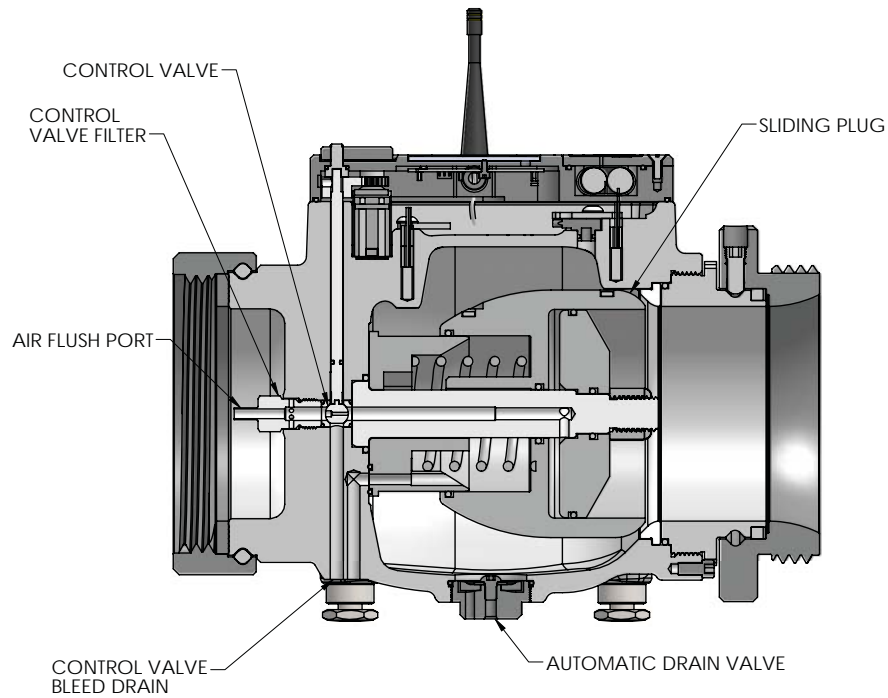
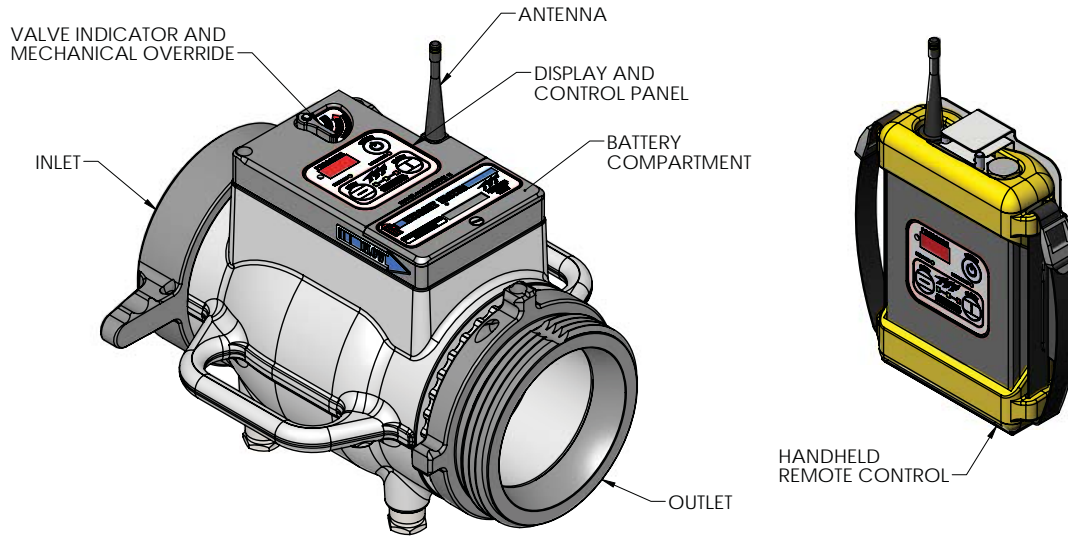

3.7 DISPLAY & CONTROL PANEL

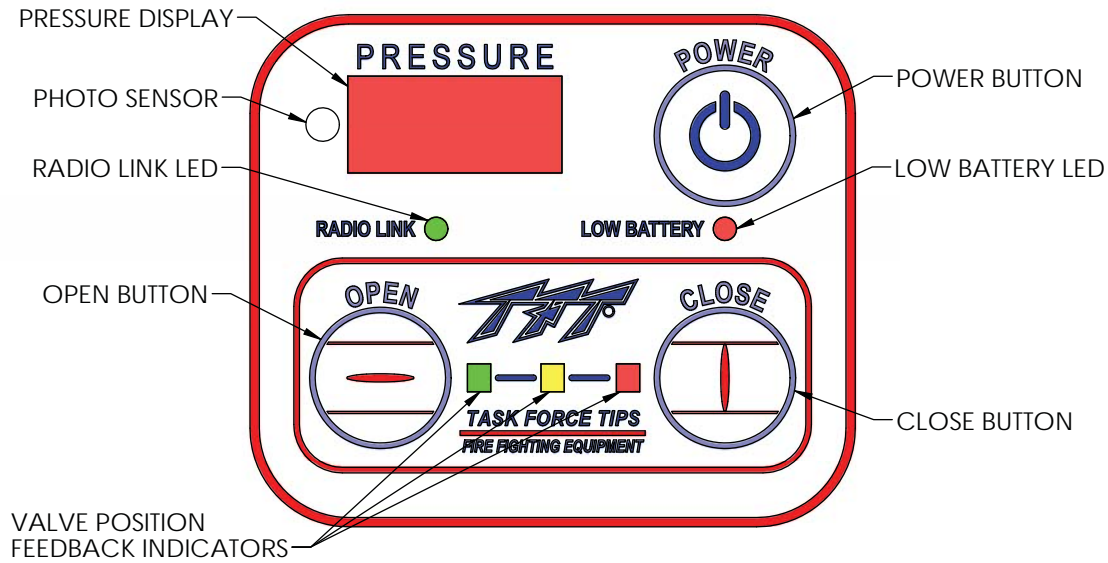

3.7.1 PRESSURE DISPLAY

Pressure remote controls will flash when valve is turned on. The pressure display shows the current hydrant pressure on both valve and handheld while valve is in use. When inlet pressure exceeds 250psi, "HI" is displayed.

3.7.2 PHOTO SENSOR

Turns backlighting on in low-light situations. Adjusts display brightness to improve readability in sunlight.

3.7.3 BUTTONS

BUTTON	FUNCTION
Power	Turns unit on and off *
Open	Opens valve
Close	Closes valve

* Valve will not turn off with button press if pressure exceeds 5 psi (0.3 bar).

3.7.4 LEDS

LED	COLOR	STATUS	MEANING
Radio Link	Green	On	Radio link present between valve and handheld remote control.
Radio Link	Green	Off	Radio link not present. Move handheld remote control closer to valve.
Low Battery	Red	Off	Battery voltage is adequate to power valve or handheld.
Low Battery	Red	Blinking	Battery voltage is low. Replace Batteries. See Section 6.1 Replacing Batteries .

3.7.5 VALVE POSITION INDICATORS

The Hydrant Master is equipped with a valve position feedback system to indicate the control valve position and actual sliding plug position.

LED	STATUS	CONTROL VALVE POSITION	ACTUAL SLIDING PLUG POSITION
Green	On	Open	Fully open position
Yellow & Green	Alternating	Open	Moving to open position
Yellow & Red	Alternating	Closed	Moving to closed position
Yellow	On	Unknown	Between open and closed position
Yellow	Flashing	Unknown	No position feedback to handheld
Red	On	Closed	Fully closed position

3.8 POWER SAVE MODE

The Hydrant Master is equipped with a power save mode. The valve automatically enters the power save mode when no buttons have been pressed for five minutes. The display and backlighting will turn off. The valve position feedback system will continue to update and flash the current position every 3 seconds. To exit power save mode, push either the open or closed button. The handheld remote control will automatically power down after five minutes of no button presses. Turning the handheld remote control back on will not change the valve's position.

3.9 VALVE POSITION INDICATOR & MECHANICAL OVERRIDE

The valve is equipped with a valve indicator which shows the position of the control valve. The sliding plug will be open when the control valve is open and there is more than 5psi (0.3 bar) pressure. The valve indicator can be used as a mechanical override in case of electronic failure. Swing the arm to the open position to open the valve or to the closed position to close the valve.

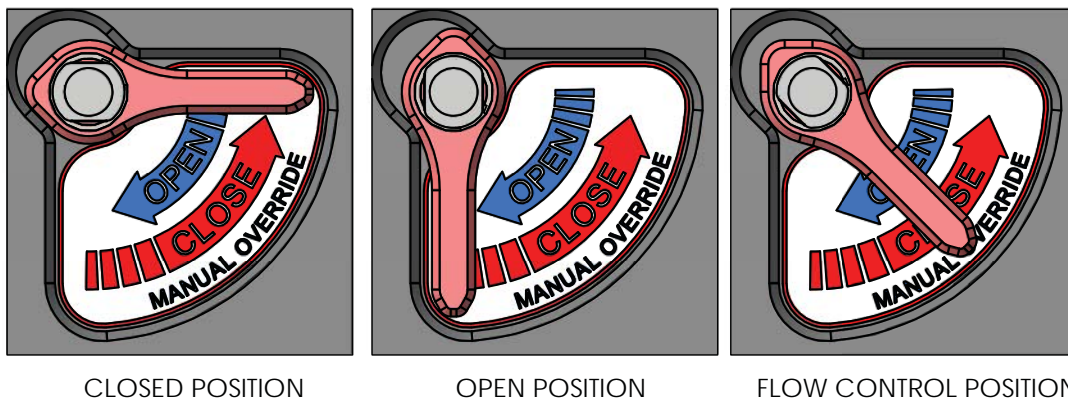
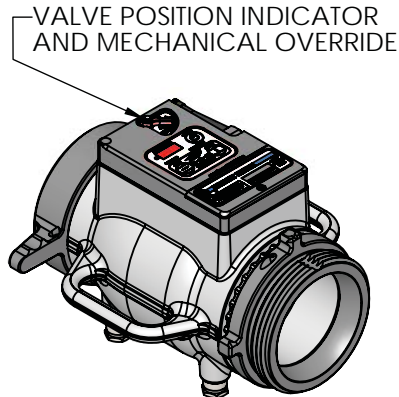

3.10 FLOW CONTROL FEATURE

The Hydrant master is equipped with a flow controlling program to maintain a maximum flow of 1000 gpm for the first 15 seconds the valve is opening. The valve position indicator will move to the full open position, move back to the flow control position, and then return to the full open position after 15 seconds. The flow controlling program prevents a hose line from charging at a rapid rate and helps avoid water hammer situations.

WARNING Minimum operating pressure 5 psi (0.3 bar). Inadequate water pressure will prevent valve from opening and may result in a lack of water flow and cause injury or death to persons dependant on water flow. Ensure there is adequate water pressure supplied to inlet of valve.

3.11 AUTOMATIC DRAIN

The Hydrant Master is equipped with an automatic drain that will empty trapped water from the main waterway of the valve. The automatic drain closes when the internal pressure is approximately 5 psi (0.3 bar) or above and opens when the internal pressure is below 5psi (0.3 bar).

3.12 AIR FLUSH PORT

The valve is equipped with an air flush port. Remove the cap. Use a standard air chuck to apply a minimum of 20 psi (1.4 bar) to the air flush port. Open and close the control valve. Residual water will be forced out through the filter and control valve bleed drain.

CAUTION The sliding plug is pinch hazard that can cause injury. Keep hands and fingers outside of the valve any time air is applied to air flush port.

4.0 INSTALLATION & CONFIGURATION

4.1 VALVE STORAGE BRACKET INSTALLATION

A storage bracket is available for the Hydrant Master. The valve can be stored with hose pre-connected to the inlet and/or outlet of the valve. The storage bracket can be mounted vertically or horizontally as shown with the included self-tapping stainless steel screws. The bracket requires 12.5" x 11.1" (317.5mm x 281.9mm) of panel space.

To purchase a bracket, order TFT part number AU-BRACKET.

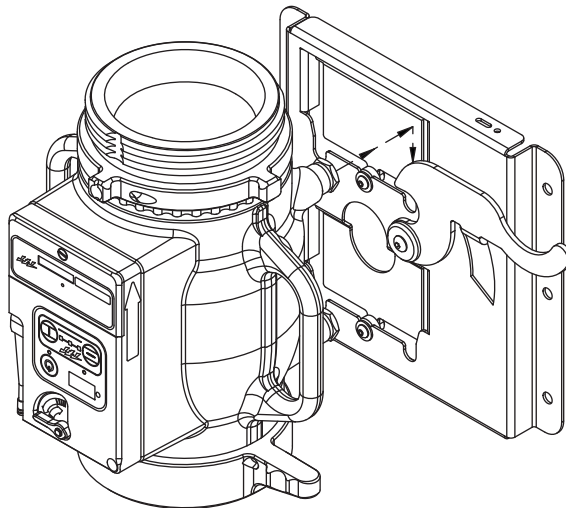

4.2 HANDHELD REMOTE CONTROL STORAGE BRACKET INSTALLATION

The storage bracket for the handheld remote control is supplied with (3) 1/4-20 stainless steel self-tapping screws. Make sure the area on the backside of the mounting surface is clear of obstructions. A minimum thickness of 3/32" (.093" – 2.4mm) in aluminum or 5/64" (.078" – 2mm) in steel is recommended. See the chart below to determine the correct pilot hole size.

Select proper location for mounting storage bracket. Panel space required will be 6.0" x 11.2" (152 x 285mm). Refer to graphic below for dimensions. Bracket can be used as a template. Be sure spring is in position.

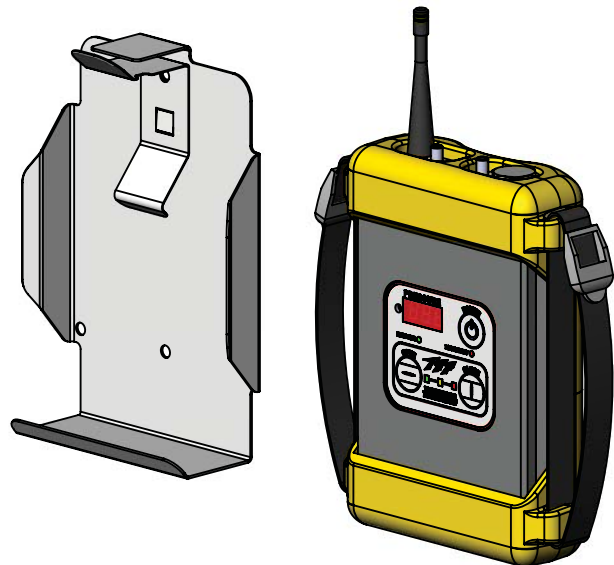
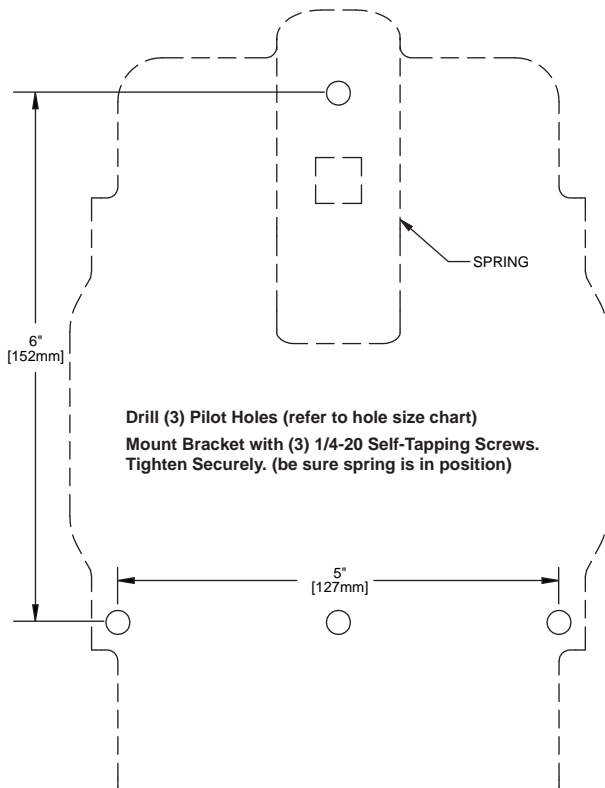

Hole Size Chart For Self Tapping Screws

ALUMINUM				STEEL			
Material Thickness	Hole Size		Use Drill	Material Thickness	Hole Size		Use Drill
	Inches	mm			Inches	mm	
5/64-3/32	.206	5.2	#5	3/32	.213	5.4	#3
1/8	.213	5.4	#3	1/8	.221	5.6	#2
3/16	.221	5.6	#2	3/16	.228	5.8	#1

4.3 CONFIGURING HANDHELD REMOTE CONTROL

Every valve has a unique ID code that allows multiple valves to be used in one location without interference. This unique ID code must be “taught” or “transferred” to the handheld remote control. Each valve’s primary wireless handheld remote control will be shipped from the factory pre-taught. The valve can be controlled with secondary handheld remote controls. Secondary handheld remote control must be taught the valve’s unique ID code. Perform the following procedure to teach the handheld remote control.

NOTE: Before teaching, valve should be powered down.

NOTE: If multiple valves are present, apply power only to the valve being taught, otherwise possible conflicts may occur.

NOTE: If handheld remote control is unable to be taught, it will exit teach mode by powering down after one minute.

1. On handheld remote control:
 - Press and hold the Open and Closed buttons.
 - Press and release the Power button.
 - Continue to hold the Open and Closed buttons for 3 seconds.
 - Three decimal points on the display will turn on, indicating the Handheld remote control is in Teach Mode.
 - Release the Open and Closed buttons.
2. On Valve:
 - Press and hold the Open and Closed buttons.
 - Press and release the Power button.
 - Continue to hold the Open and Closed buttons for 3 seconds.
 - Three decimal points on the display will turn on, indicating the valve is in Teach Mode.
 - Release the Open and Closed buttons.
 - The display will toggle between three bars on bottom and three bars on top while the ID is being transmitted to the Handheld.
3. The handheld will automatically exit the teach mode upon successfully receiving a valid ID. The Radio Link LED will be lit for 5 seconds.
4. Cycle power off and back on to valve to complete the process.

5.0 USE

5.1 PREPARING VALVE FOR USE

The Hydrant Master **MUST** be hooked to hose or hydrant on **BOTH** sides of the valve before use.

BEFORE USE

SAFETY

Make connections to hydrant or fire hose on each side of valve.

Ensure that flow will move in the direction indicated on the valve.

⚠ WARNING

Valve will not properly open or close if flow direction does not match arrow printed on exterior of valve. Reducing or interrupting of flow may cause injury or death to persons dependent on water flow.

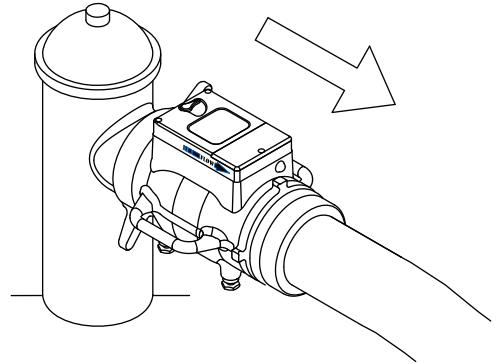

Verify that valve indicator is in closed position to ensure that valve is closed.

⚠ CAUTION

Pressurizing hydrant with valve in open position could prematurely charge hose line.

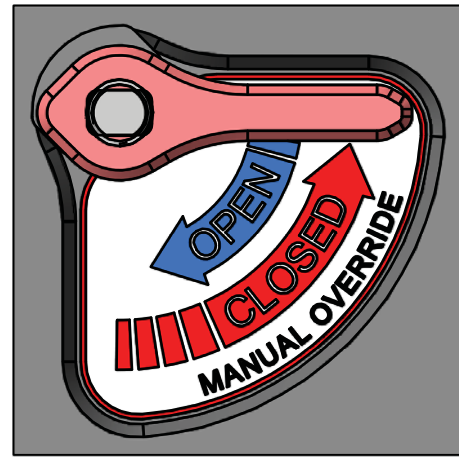

Raise antenna on valve.

⚠ CAUTION

Leaving antenna in the lowered position may reduce range of handheld remote control.

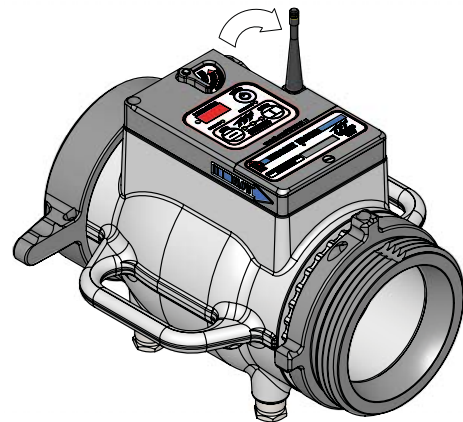

⚠ CAUTION

Dissimilar metals coupled together can cause galvanic corrosion that can result in the inability to unscrew the threads and complete loss of thread engagement over time. Per NFPA 1962 (2008 edition), if dissimilar metals are left coupled together, an anti-corrosive lubricant should be applied to the threads. Also, the coupling should be disconnected and inspected at least quarterly.

⚠ CAUTION

Use care when handling male fire hose couplings. Threads are sharp and can cause injury when mishandled.

5.2 OPERATOR INSTRUCTIONS AND VALVE FUNCTION

OPERATOR INSTRUCTIONS
Open hydrant to pressurize valve.
Use Power button to activate handheld remote control.
VALVE FUNCTION
Pressure inside valve exceeding 10 psi automatically activates valve electronics.
POSITION FEEDBACK
Constant red LED indicates valve is closed.

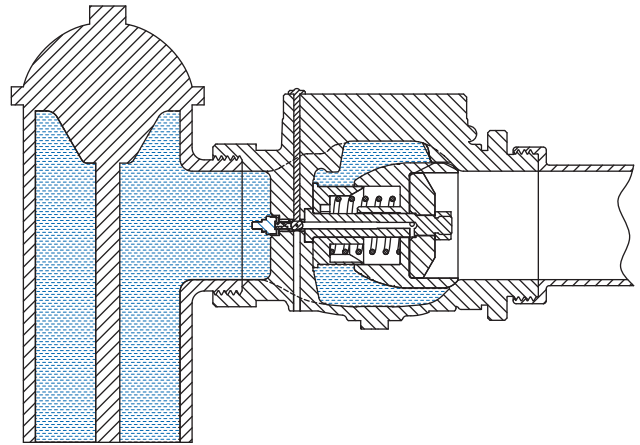

OPERATOR INSTRUCTIONS
When water is required, push the Open button on handheld remote control or valve.
VALVE FUNCTION
Electronics opens control valve, allowing water pressure to build in control chamber and open sliding plug.
POSITION FEEDBACK
Flashing yellow & green LEDs indicate sliding plug is moving to open position.
Constant green LED indicates sliding plug in fully open position.

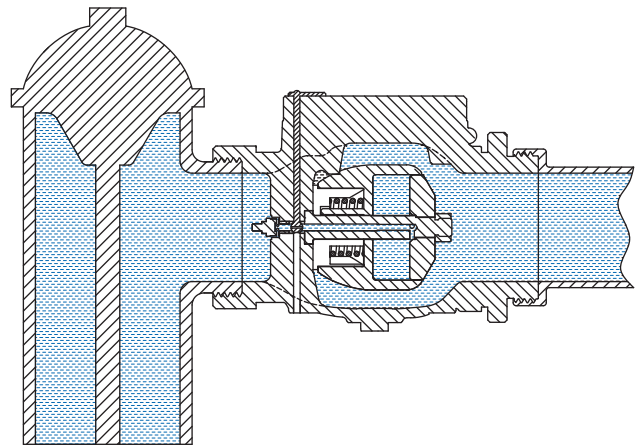

OPERATOR INSTRUCTIONS
When water is no longer desired, push the Close button on handheld remote control or valve.
VALVE FUNCTION
Electronics closes control valve, allowing the water from control chamber to drain to ground and close sliding plug.
POSITION FEEDBACK
Flashing red & yellow LEDs indicate sliding plug is moving to closed position.
Constant red LED indicates sliding plug in fully closed position.

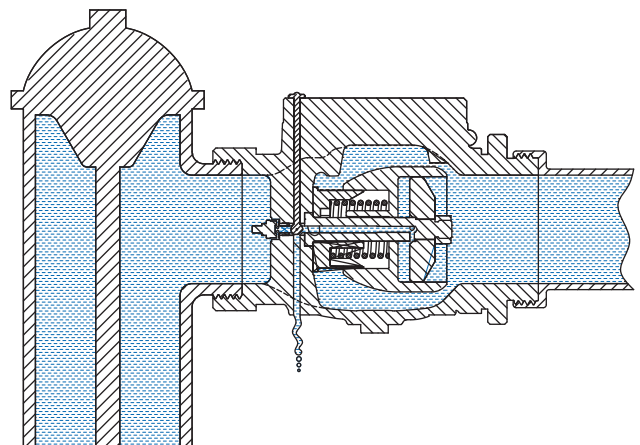

5.3 PRESSURE LOSS

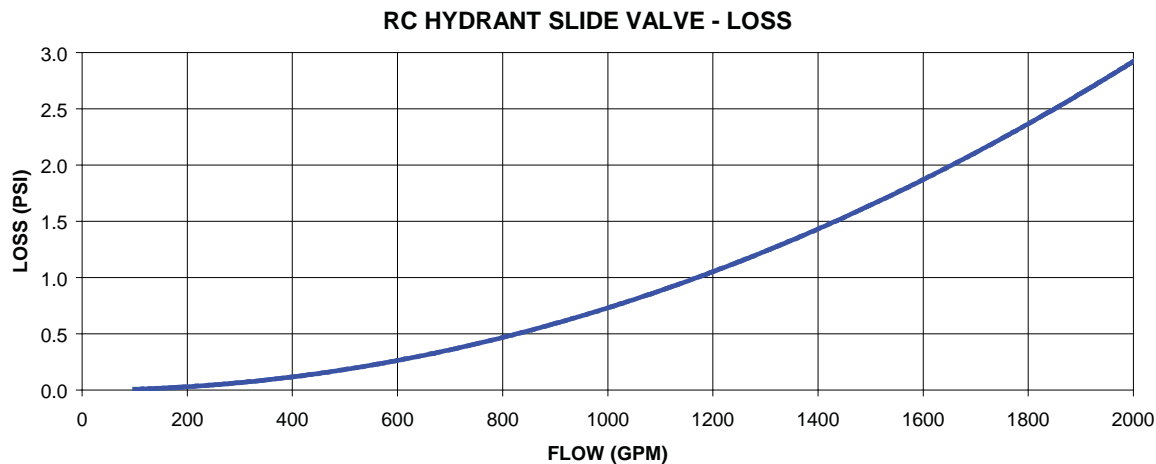

6.0 MAINTENANCE

This valve should be disconnected, cleaned and visually inspected inside and out at least quarterly for proper function per NFPA 1962 Section 8.2, or as water quality and use may require. Moving parts should be checked for smooth and free operation. Seals shall be greased as needed with a silicone-based grease such as Dow Corning 112. Any scrapes that expose bare aluminum should be cleaned and touched up with enamel paint such as Rust-Oleum.

In particular assure that:

- There is no damage such as cracks or dents
- There is no corrosion
- The waterway is clear of obstructions
- The sliding plug moves freely (Use Air Flush Port to test according to section [3.12 AIR FLUSH PORT](#))

Replace any missing or damaged parts before returning to service. Any repaired device must be tested before being placed in service.



Any alterations to the device and its markings could diminish safety and constitute a misuse of this product.

6.1 CHANGING BATTERIES

HANDHELD CONTROLLER

- Four (AA) Batteries required, Lithium strongly recommended.
- Remove two (2) screws on backside of handheld remote control.
- Slide bottom half of rubber bumper off enclosure.
- Replace batteries, verifying polarity is correct.
- Replace bumper and retaining screws.

VALVE

- Four (AA) Batteries required, Lithium strongly recommended.
- Remove retaining screw from battery compartment lid.
- Slide lid open.
- Replace batteries, verifying polarity is correct.
- Insure o-ring is undamaged and in place.
- Replace lid and retaining screw.



Properly dispose of old batteries. Do not puncture, incinerate, or disassemble batteries. Do not mix battery types.

6.2 TROUBLESHOOTING

SYMPTOM	POSSIBLE CAUSE	REMEDY	REFERENCE
No power LED.	Low or drained batteries	Replace batteries	6.1 CHANGING BATTERIES
Power LED on but no operation.	Battery voltage too low	Replace batteries	6.1 CHANGING BATTERIES
Display reads "No Radio"	Radio board has failed or has been disconnected.	Consult Task Force Tips Service Department	
No radio link LED. Handheld remote control does not operate valve, valve controls do work.	Handheld is out of range.	Move handheld closer to valve or eliminate interference.	
	Valve and handheld remote control are not linked properly.	Teach handheld.	4.3 SECONDARY HANDHELD REMOTE CONTROL
	Radio board has failed or has been disconnected	Consult Task Force Tips Service Department	
Handheld is flashing yellow LED	Valve is off.	Power up valve.	4.3 SECONDARY HANDHELD REMOTE CONTROL
	Valve and handheld remote control are not linked properly.	Teach handheld.	
Control valve opens but yellow and green LEDs continue to flash.	Valve is installed backwards	Reinstall valve so flow arrow matches flow direction.	5.1 PREPARING VALVE FOR USE
	Inadequate pressure.	Increase inlet pressure.	
	Debris or ice in control passages.	Clear control passages.	3.12 AIR FLUSH PORT
	Valve position feedback system malfunctioning.	Consult Task Force Tips Service Department.	
Red and Green LEDs flashing	Valve position feedback system malfunctioning	Consult Task Force Tips Service Department.	
Pressure display reads "Hi"	Inlet pressure is above 250psi.	Decrease inlet pressure.	

7.0 EXPLODED VIEW

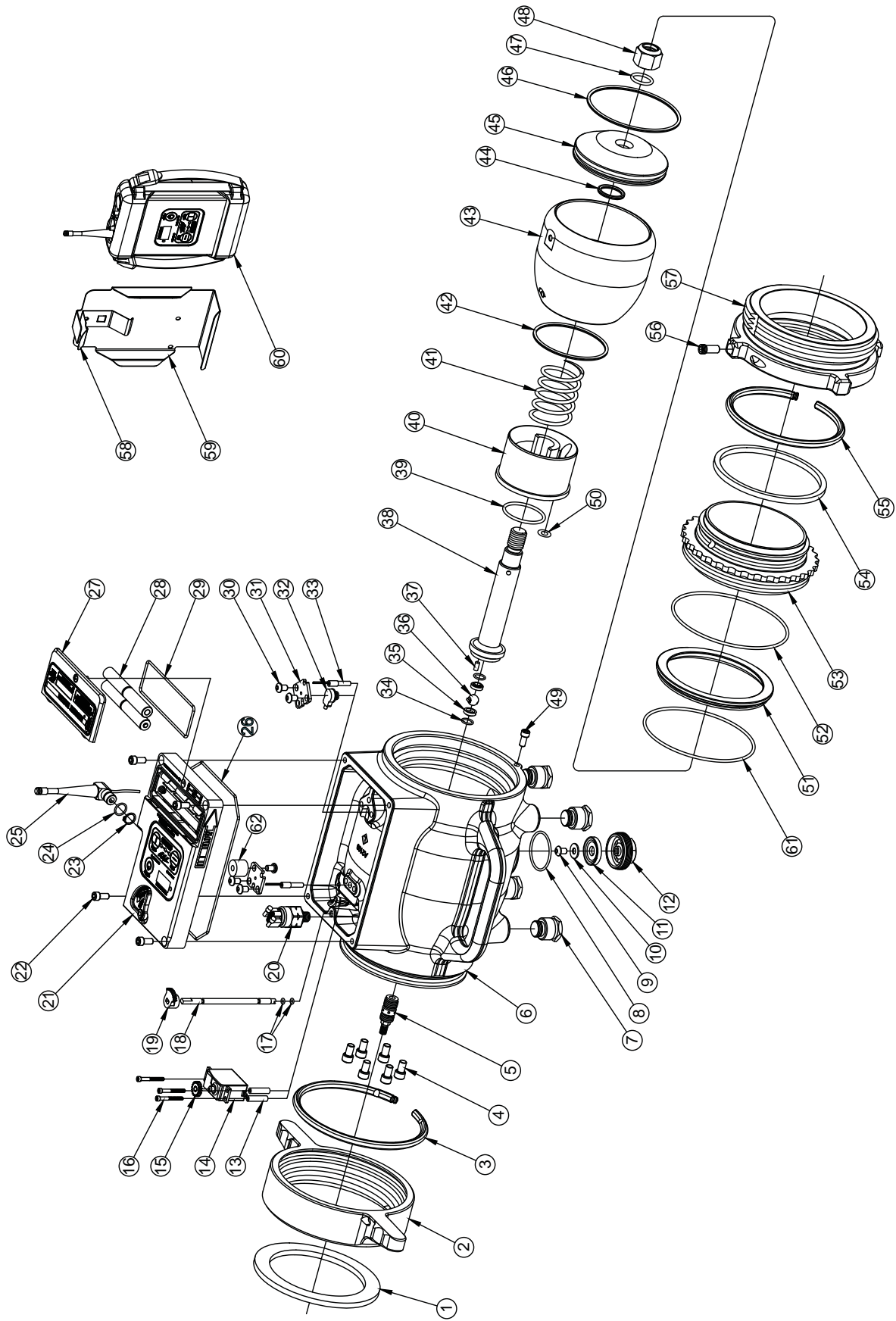

7.1 PARTS LIST

ID	QTY	PART #	DESCRIPTION
1	1	SEE CHART	GASKET
2	1	SEE CHART	INLET COUPLING
3	1	SEE CHART	PLASTIC STRIP
4	6	VT31-18SH1.0	5/16-18 X 1 SOCKET HEAD SCREW
5	1	A2120	CONTROL VALVE FILTER
6	1	SEE CHART	VALVE BODY
7	4	A2037	MOUNTING FOOT
8	1	VO-130	O-RING-130
9	1	VT25-28BH500	1/4-28 X 1/2 BUTTON HEAD SCREW
10	1	VW687X281-50	FLAT WASHER 1/4"
11	1	X382	DRAIN VALVE
12	1	X375	DRAIN HOUSING
13	3	A2135	SPACER - .14ID X 1.00LONG
14	1	A2210	SERVO - FUTABA
15	1	A2132	GEAR
16	3	VT06-32SH1.2	6-32 X 1 1/4 SOCKET HEAD SCREW
17	2	VO-190	O-RING .132" ID .070" C/S
18	1	A2123	CONTROL VALVE SHAFT
19	1	A2131	GEAR
20	1	A2215	SWITCH - PRESSURE 10 PSI
21	1	A2185	ELECTRONICS COMPARTMENT LID
22	4	VT25-20SH500	1/4-20 X 1/2 SOCKET HEAD SCREW
23	1	VR4250	SNAP RING 1/2" EXTERNAL X .035
24	1	VO-014	O-RING-014
25	1	A2230	ANTENNA - 1/4 WAVE
26	1	VO-167	O-RING-167
27	1	A2141	BATTERY COMPARTMENT LID
28	4	---	BATTERY - AA 1.5 VOLT LITHIUM
29	1	VO-154	O-RING-154
30	4	VT25-20BH375	1/4-20 X 3/8 BUTTON HEAD SCREW

ID	QTY	PART #	DESCRIPTION
31	2	A2136	TRANSDUCER RETAINER
32	1	A5845	TRANSDUCER - PRESSURE
33	2	A2220	SWITCH - REED
34	2	VO-013	O-RING-013
35	2	A2121	CONTROL VALVE SEAT
36	1	A2122	CONTROL VALVE BALL
37	1	VP188X.375	DOWEL PIN .188DIA X .375LONG
38	1	A2110	VALVE SHAFT
39	1	VO-224	O-RING-224
40	1	A2111	VALVE SLEEVE
41	1	A2126	RETURN SPRING
42	1	VOQ-4236	QUAD-RING-4236
43	1	A2112	SLIDING PLUG
44	1	VOQ-4214	QUAD-RING-4214
45	1	A2113	VALVE SHAFT END
46	1	VOQ-4243	QUAD-RING-4243
47	1	VO-211	O-RING-211
48	1	VT75-10LNT	3/4" LOCK NUT
49	1	VT25-20SH500	1/4-20 X 1/2 SOCKET HEAD SCREW
50	1	VO-111	O-RING-111
51	1	A2114	VALVE SEAT
52	1	VO-252	O-RING-252
53	1	SEE CHART	OUTLET MATE
54	1	SEE CHART	CUP SEAL
55	1	SEE CHART	PLASTIC STRIP
56	1	SEE CHART	LOCKOUT SCREW
57	1	SEE CHART	OUTLET COUPLING
58	1	Y5946	LATCH SPRING
59	1	Y5945	HOLSTER
60	1	A2270	WIRELESS HANDHELD
61	1	VO-250	O-RING-250

7.2 INLET COMPONENTS

ID	QTY	DESCRIPTION	4.0" STORZ	5.0" STORZ	6.0" STORZ	4.0" FEMALE	4.5" FEMALE	5.0" FEMALE
6	1	VALVE BODY	A2101	A2101	A2101	A2101	A2100	A2100
1	1	GASKET	--	--	--	V3198	V3210	V3220
2	1	INLET COUPLING	A4124	A4125	A4126	A4562N	A4568NR	A4573NT
3	1	PLASTIC STRIP	A1292	A1291	A1291	A1291	A1293	A1293
	1	CUP SEAL	A1597	A1596	A1596	--	--	--
	1	LOCKOUT SCREW	A1294	A1294	A1294	--	--	--
	1	NFS RING	--	--	--	A4561	--	--
	1	O-RING	--	--	--	VO-248	--	--
	1	MATE PSM4.25 X PSF5.25	A4730	--	--	--	--	--
	1	CUP SEAL	A1596	--	--	--	--	--
	1	PORT COVER	A1298	--	--	--	--	--
	1	PLASTIC STRIP	A1291	--	--	--	--	--

7.3 OUTLET COMPONENTS

ID	QTY	DESCRIPTION	4.0" STORZ	5.0" STORZ	6.0" STORZ	4.0" MALE	4.5" MALE	5.0" MALE
53	1	OUTLET MATE	A2115	A2115	A2115	A2115	A2115	A2115
54	1	CUP SEAL	A1597	A1596	A1596	A1596	A1596	A1596
55	1	PLASTIC STRIP	A1292	A1291	A1291	A1291	A1291	A1291
56	1	LOCKOUT SCREW	A1294	A1294	A1294	A1294	A1294	A1294
57	1	OUTLET COUPLING	A4124	A4125	A4126	A4620N	A4625N	A4630N
	1	PORT COVER	A1298	--	--	--	--	--
	1	PORT PLUG	A1299	A1299	A1299	A1299	A1299	A1299
	1	MATE PSM4.25 X PSF5.25	A4730	--	--	--	--	--
	1	CUP SEAL	A1596	--	--	--	--	--
	1	PLASTIC STRIP	A1291	--	--	--	--	--

8.0 WARRANTY

Task Force Tips, Inc., 3701 Innovation Way, Valparaiso, IN 46383-9327 (*TFT*) warrants to the original purchaser of its Hydrant Master (*equipment*), and to anyone to whom it is transferred, that the equipment shall be free from defects in material and workmanship during the five (5) year period from the date of purchase.

TFT's obligation under this warranty is specifically limited to replacing or repairing the equipment (or its parts) which are shown by TFT's examination to be in a defective condition attributable to TFT. To qualify for this limited warranty, the claimant must return the equipment to TFT, at 3701 Innovation Way, Valparaiso, IN 46383-9327, within a reasonable time after discovery of the defect. TFT will examine the equipment. If TFT determines that there is a defect attributable to it, TFT will correct the problem within a reasonable time. If the equipment is covered by this limited warranty, TFT will assume the expenses of repair.

If any defect attributable to TFT under this limited warranty cannot be reasonably cured by repair or replacement, TFT may elect to refund the purchase price of the equipment, less reasonable depreciation, in complete discharge of its obligations under this limited warranty. If TFT makes this election, claimant shall return the equipment to TFT free and clear of any liens and encumbrances.

This is a limited warranty. The original purchaser of the equipment, any person to whom it is transferred, and any person who is an intended or unintended beneficiary of the equipment, shall not be entitled to recover from TFT any consequential or incidental damages for injury to person and/or property resulting from any defective equipment manufactured or assembled by TFT. It is agreed and understood that the price stated for the equipment is in part consideration for limiting TFT's liability. Some states do not allow the exclusion or limitation of incidental or consequential damages, so the above may not apply to you.

TFT shall have no obligation under this warranty if the equipment is, or has been, misused or neglected (including failure to provide reasonable maintenance) or if there have been accidents to the equipment or if it has been repaired or altered by someone else.

THIS IS A LIMITED EXPRESS WARRANTY ONLY. TFT EXPRESSLY DISCLAIMS WITH RESPECT TO THE EQUIPMENT ALL IMPLIED WARRANTIES OF MERCHANTABILITY AND ALL IMPLIED WARRANTIES OF FITNESS FOR A PARTICULAR PURPOSE. THERE IS NO WARRANTY OF ANY NATURE MADE BY TFT BEYOND THAT STATED IN THIS DOCUMENT.

This limited warranty gives you specific legal rights, and you may also have other rights which vary from state to state.