



MANUAL: Jumbo Gate Valve™

INSTRUCTIONS FOR SAFE OPERATION AND MAINTENANCE

⚠ WARNING

Read instruction manual before use. Operation of this device without understanding the manual and receiving proper training is a misuse of this equipment. A person who has not read and understood all operating and safety instructions is not qualified to operate the Jumbo Gate Valve.

This instruction manual is intended to familiarize firefighters and maintenance personnel with the operation, servicing and safety procedures associated with the Jumbo Gate Valve.

This manual should be kept available to all operating and maintenance personnel.

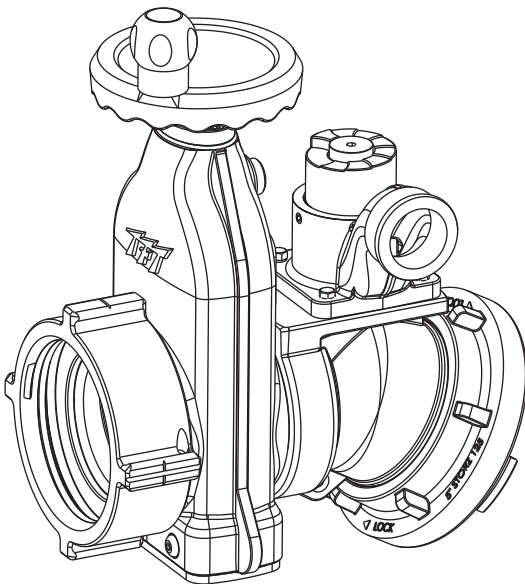

OPERATING RANGE:
Pressure Max. 250 PSI
Pressure Min. Full Vac.

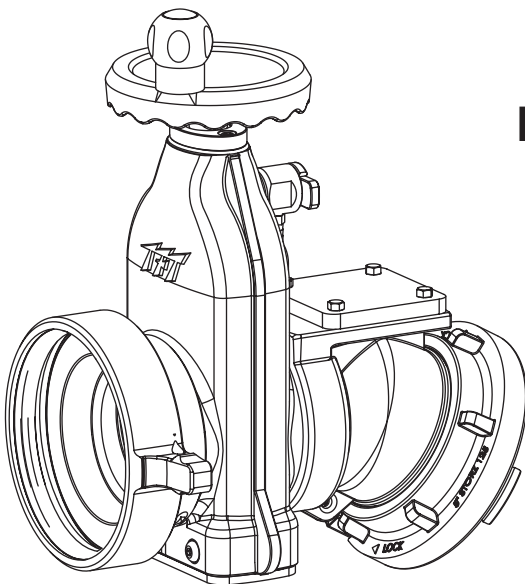

**Hydrostatic
Proof Test:
900 PSI**

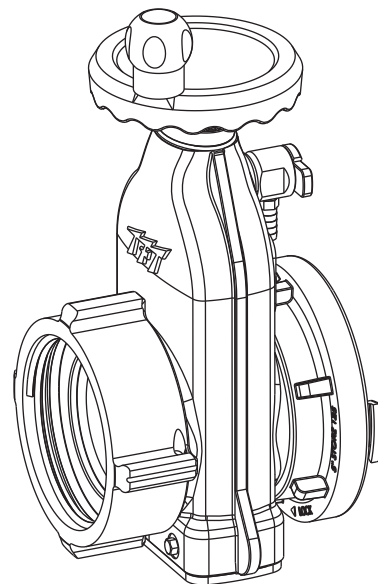

TASK FORCE TIPS, Inc.
Made in USA • www.tft.com

2800 E Evans Ave • Valparaiso, IN 46383-6940 USA
800-348-2686 • 219-462-6161 • Fax 219-464-7155

TABLE OF CONTENTS

- 1.0 MEANING OF SIGNAL WORDS
 - 1.1 SAFETY
- 2.0 GENERAL INFORMATION
 - 2.1 CORROSION
 - 2.2 USE WITH SALT WATER
- 3.0 INSTALLATION
- 4.0 USE
 - 4.1 VALVE OPEN AND CLOSE
- 5.0 AIR VENT
 - 5.1 CHANGING SIDES FOR VENTED AIR
- 6.0 PRESSURE RELIEF VALVE
 - 6.1 RELIEF VALVE SETTING PRESSURE
 - 6.2 RELIEF VALVE FLOW vs. PRESSURE CURVE
- 7.0 DRAWINGS AND PART LISTS
- 8.0 MAINTENANCE
- 9.0 WARRANTY

1.0 MEANING OF SIGNAL WORDS

A safety related message is identified by a safety alert symbol and a signal word to indicate the level of risk involved with a particular hazard. Per ANSI standard Z535.4-1998 the definitions of the three signal words are as follows:

⚠ DANGER

DANGER indicates an imminently hazardous situation which, if not avoided, will result in death or serious injury.

⚠ WARNING

WARNING indicates a potentially hazardous situation which, if not avoided, could result in death or serious injury.

⚠ CAUTION

CAUTION indicates a potentially hazardous situation which, if not avoided, may result in minor or moderate injury.

1.1 SAFETY

⚠ WARNING

This equipment is intended for use by trained personnel for firefighting. Its use for other purposes may involve hazards not addressed by this manual. Seek appropriate guidance and training to reduce risk of injury.

⚠ WARNING

Burst hoses and fittings can result in injury or death. Maximum operating pressure of TFT's Jumbo Gate Valve is 250 psi (17 bar). Do not exceed 250 PSI on either side of valve.

*Per NFPA 1962 3 1/2 to 5 inch (90-127 mm) hose marked SUPPLY HOSE shall not exceed 185 PSI (13 bar).
Per NFPA 1962 6 inch (152 mm) hose marked SUPPLY HOSE shall not exceed 135 psi (9 bar).*

2.0 GENERAL INFORMATION

The Jumbo Gate Valve is intended for use on the intake manifold of a fire engine, fire hydrant, or in a hose line. When used on a fire engine, the valve is kept closed while the water supply from a hydrant or another pumper to the engine is being established. This prevents the pump from sucking air through the intake manifold and losing its prime. Once the supply hose is filled and under pressure, and the air has been vented from the hose, the valve may be opened to connect the pump to the water supply.

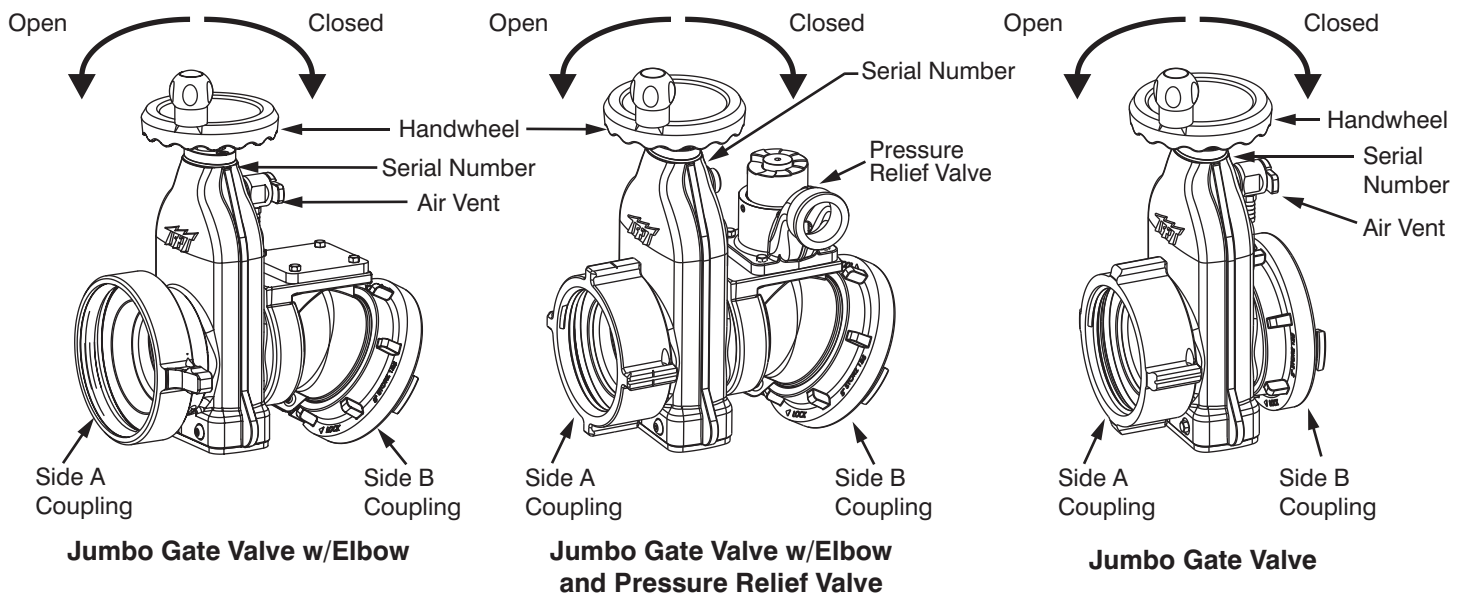

Note: If the pressure relief valve is mounted on top of the elbow, the air vent will be mounted on the side of the elbow.

2.1 CORROSION

The aluminum castings are plastic impregnated, hardcoat anodized, and TFT powdercoat finished inside and out for maximum corrosion protection. Unique stainless steel wedge gate with polymer seats results in low wear and bi-directional sealing. Hose couplings are attached using polymer bearing rings which provides electrical isolation to help prevent galvanic corrosion. The effects of corrosion can be minimized by good maintenance practices. See Section 7.0 for maintenance.

2.2 USE WITH SALT WATER

Use with salt water is permissible provided valve is thoroughly cleaned with fresh water after each use. The service life of the valve may be shortened due to the effects of corrosion and is not covered under warranty.

3.0 INSTALLATION

Make connections to fire hose or fittings on each side of valve. Valve seals in both directions. When the valve is in the fully shut off position air is bled from only one side of valve. The valve is factory assembled to bleed air from the same side as the air bleed knob is on. See section 5.1 for how to change which side air is vented from.



Warnings: Kinks in supply hose may reduce water flow and cause injury or death to persons dependant on water flow. When this valve is used on a hydrant or fire truck it is recommended that it be used with an elbow to minimize risk of hoseline kinks.



Caution: Valve must be properly connected. Mismatched or damaged connectors may cause leaking or uncoupling under pressure and could cause injury.



Caution: Male fire hose threads are sharp and can cause injury. Be careful when around male hose threads.

4.0 USE

4.1 VALVE OPEN AND CLOSE

To open the valve turn the handwheel in a counter-clockwise direction until the handwheel cannot be turned. To close, turn the handwheel the opposite way until it cannot be turned.

5.0 AIR VENT

This valve is equipped with an Air Vent which will allow the air to escape from the valve when the hose is charged. The Air Vent is opened by turning the knob counter-clockwise and closed by turning it clockwise.

The vent is tapped 1/4 NPT. A barb fitting and plastic tube may be used to run the vent behind the pump panel.



Warning: Loss of prime can interrupt water flow and cause injury or death. Always bleed out air with air bleed valve to prevent possible loss of prime. Valve can be set up to bleed air from either of its two sides. When installing valve, be aware of which side a particular valve is set up to bleed from.

5.1 CHANGING SIDES FOR VENTED AIR (JUMBO GATE VALVE ONLY)

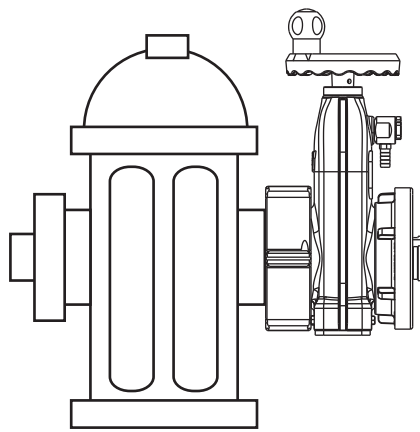
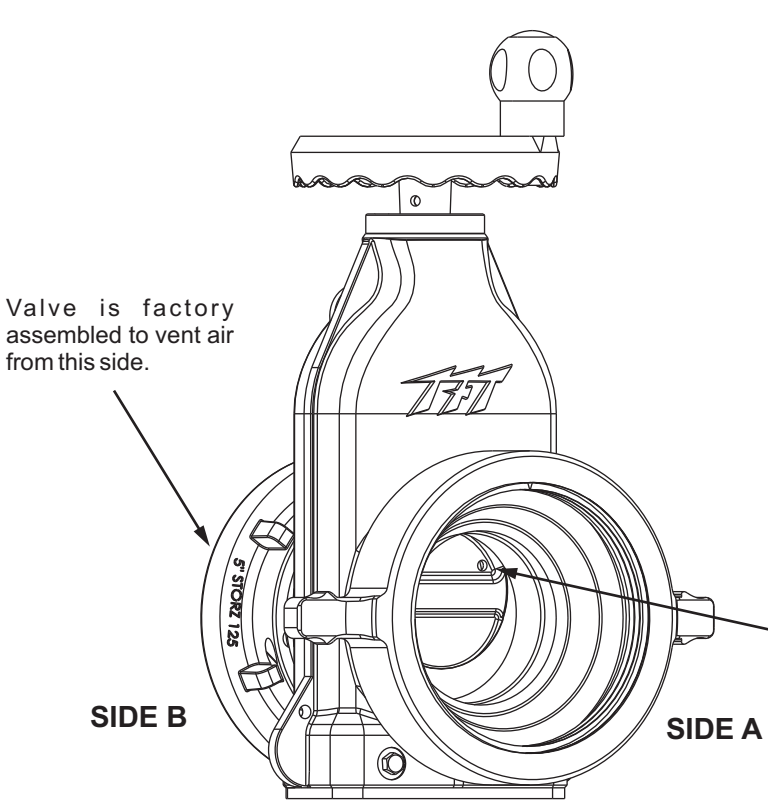

For best sealing results against a pressurized source, place pipe plug towards water supply.

Pipe Plug factory installed on this side. If it is desired to vent air from this side then remove the pipe plug and reinstall in the threaded hole on the other side.

6.0 PRESSURE RELIEF VALVE



Loss of prime can interrupt water flow and cause injury or death. Always bleed out air with air valve to prevent possible loss of prime.

If there is a pressure relief valve on the top side of the elbow, it may be set to any pressure between 50 and 200 p.s.i.. Its function is to protect the pump and the supply hose from excess pressure. The relief valve may be mounted with its opening facing the front, back, right or left. A piece of hose or tubing may be mounted on the round spout to direct the water coming out of the relief valve away from the pump panel. To change the orientation of the relief valve, remove the four 7/16 bolts on the corners of the relief valve flange, orient the valve the way you want it, and replace the bolts. Use a drop of thread locking compound on the threads of the bolt to prevent them from coming loose.

6.1 RELIEF VALVE SETTING PRESSURE

To set the relief valve pressure turn the adjusting screw on the relief valve housing until the surface of the screw is even with the desired pressure. Do not cap or plug discharge opening.

6.2 RELIEF VALVE FLOW vs. PRESSURE CURVE

PRESSURE RELIEF VALVE PERFORMANCE

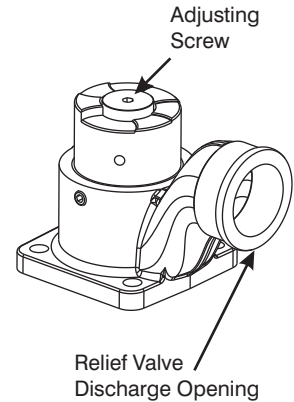
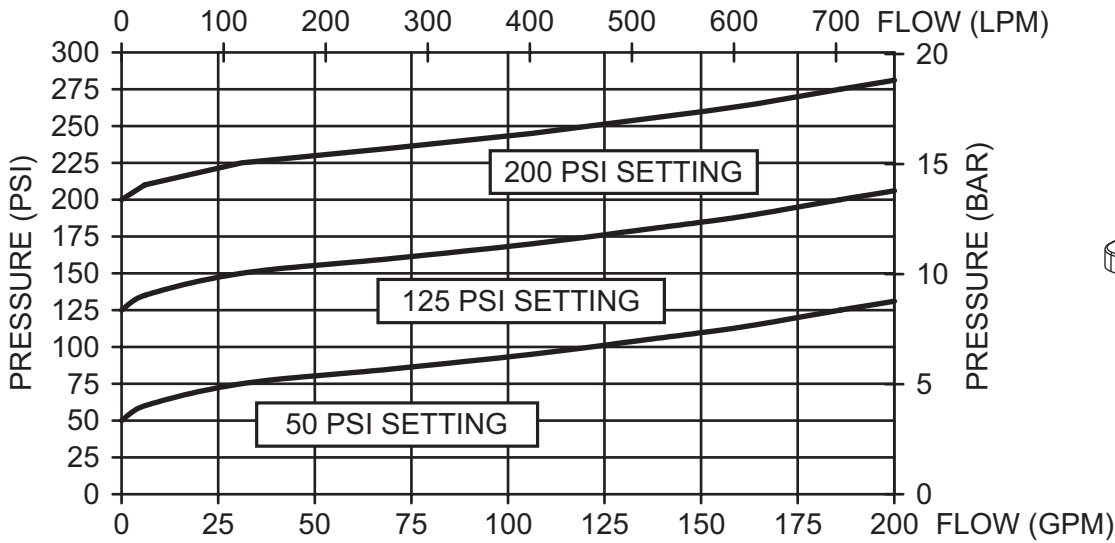

7.0 DRAWINGS AND PARTS LISTS

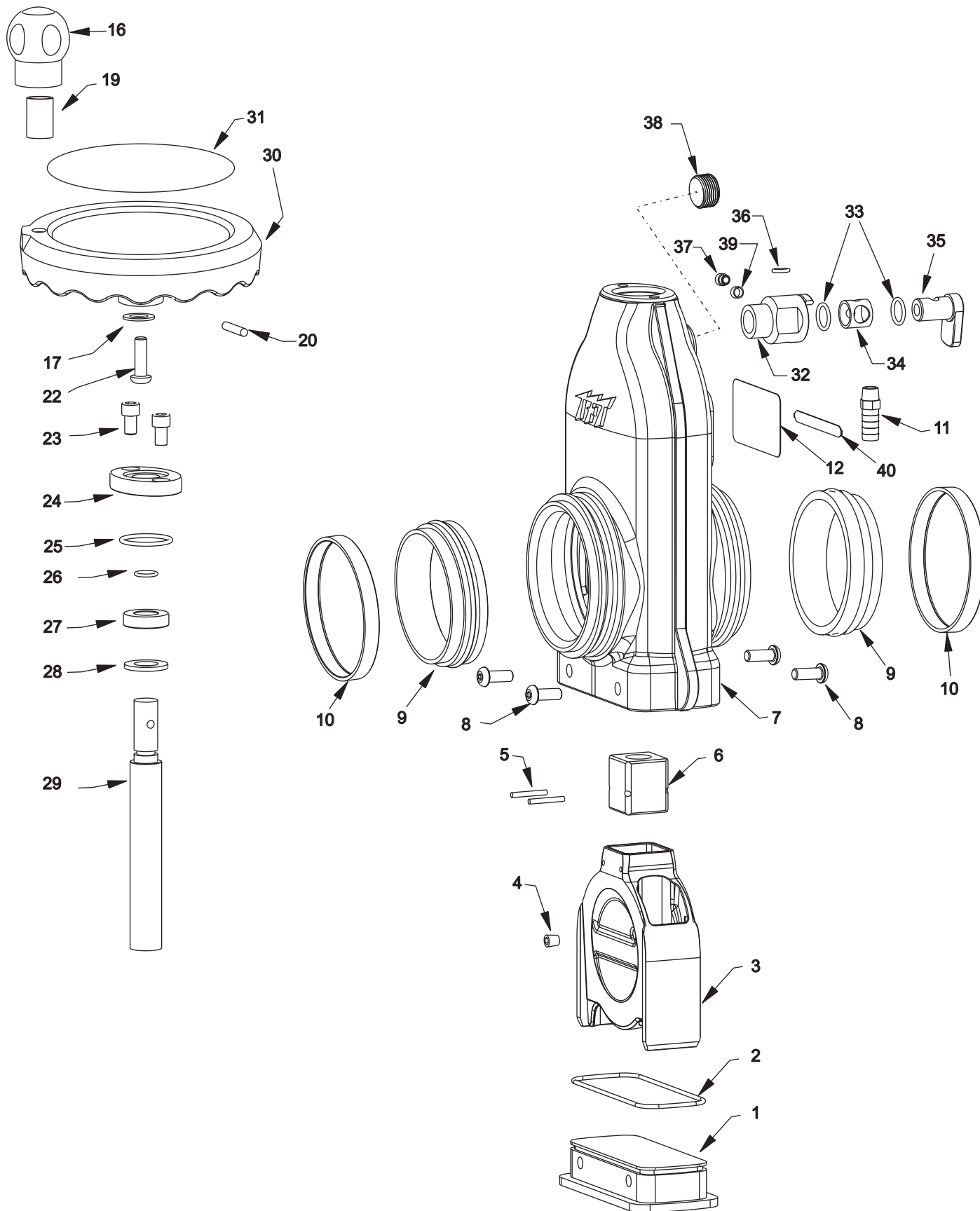

7.0 DRAWINGS AND PARTS LISTS

Table 1: Jumbo Gate Valve Parts List

#	Part Description	Part #	Qty
1	BOTTOM COVER	A5510	1
2	O-RING-247	VO-247	1
3	BLADE	A5540	1
4	1/8 NPT PLUG - HEX SOCKET	VFSP1M-SS	1
5	5/32 X 1-3/4 HD SPIROL PIN	VP156X1.75HD	2
6	THREADED BLOCK	A5542	1
7	GATE BODY	A5505	1
8	3/8-16 X 1 BUTTON HEAD BOLT	VT37-16BHx1.0	4
9	SEAT	A5545	2
10	SEAL	A5550	2
11	BARB FITTING	XX329	1
12	NAME LABEL - GATE VALVE	A1302	1
16	KNOB - SOFT TOUCH	A1512	1
17	WASHER .812"OD .406"ID	VW812X406-65	1
19	CRANK BUSHING	A1513	1
20	1/4 X 1-3/8 HDP SPIROL PN	VP250X1.375H	1
22	3/8-16 X 1-1/2 BUTTON HEAD	VT37-16BH1.5	1
23	5/16-18 X 3/4 SOCKET HEAD	VT31-18SH750	2
24	CRANK RETAINER	A5515	1
25	O-RING-221	VO-221	1
26	O-RING-206	VO-206	1
27	BUSHING	A5525	1
28	BLADE WASHER	A5530	1
29	ACME SCREW	A5520	1
30	HANDWHEEL	X281	1
31	NAME LABEL: GATE VALVE	A1307	1
32	DRAIN HOUSING	A1543	1
33	O-RING-115	VO-115	2
34	DRAIN SLEEVE	A1541	1
35	DRAIN LEVER	A1542	1
36	O-RING-110	VO-110	1
37	DOG POINT	H515	1
38	3/4" PIPE PLUG	XG410	1
39	FOLLOWER	U251	1
40	MODEL NUMBER LABEL	A1303	1

7.0 DRAWINGS AND PARTS LISTS

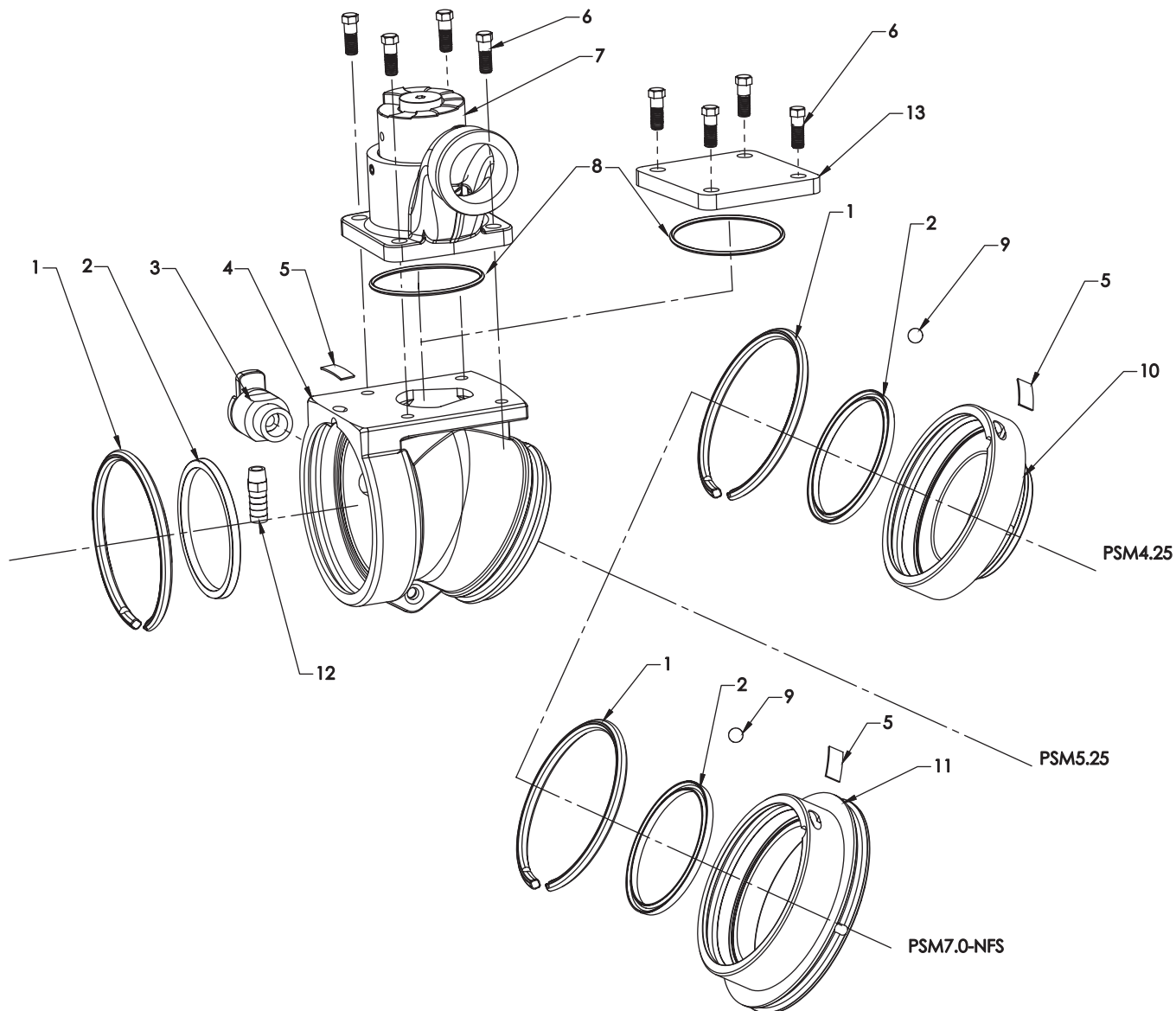

Table 2: Jumbo Gate Valve With Elbow/prv

#	DESCRIPTION	QTY	PART#
1	PLASTIC STRIP 5.25"	1	A1291*
2	CUP SEAL 5.25 X 4.75 X 1/4	1	A1296*
3	DRAIN VALVE SUBASSEMBLY	1	A1621
4	ELBOW W/PRV PSF5.25 X PSM5.25	1	A4040UU
5	LABEL; PORT COVER	1	A1298*
6	7/16-14 X 1 HEX HEAD BOLT	4	VT43-14HX1.0
7	PRESSURE RELIEF VALVE SUBASSEMBLY	1	A1640
8	O-RING-236	1	VO-236
9	BALL 7/16" STAINLESS (FOR LOCKED OUT ELBOWS)	1	VB.437**
10	MATE PSM4.25 X PSF5.25	1	A4730***
11	MATE PSF5.25 X PSM7.0-NFS	1	A4745****
12	1/2 BARB X 1/4 MNPT NIPPLE	1	XX329
13	LDH BLANK CAP	1	X631

* If either item 10 or 11 is used, this quantity will be 2.

** If neither item 10 or 11 is used, this quantity will be 0;
 If the B side is 5.0" or 6.0" female swivel handle coupling or 6.0" female swivel rocker coupling, this quantity will be 1;
 If the B side is 4.0" Storz rigid, this quantity will be 2.

*** This mate is used to connect 4.0" Storz coupling on B side.

**** This mate is used to connect 5.0" or 6.0" female swivel handle coupling or 6.0" female swivel rocker coupling on B side.

7.0 DRAWINGS AND PARTS LISTS

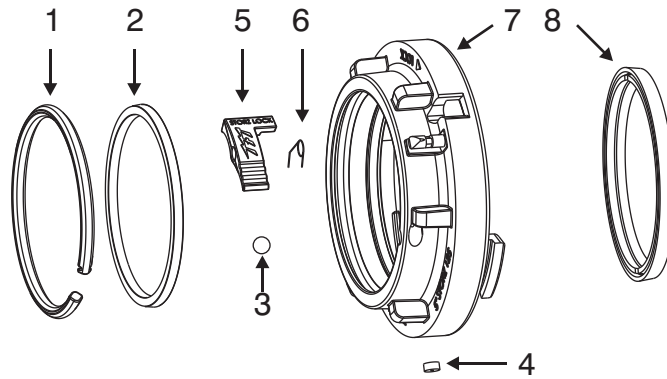

Table 3: Storz Coupling Parts List

#	Part Description	Qty	Part #
1	PLASTIC STRIP 4.25" (FOR 4 INCH STORZ)	1	A1292
	PLASTIC STRIP 5.25"	1	A1291
2	CUP SEAL 4.25 X 3.75 X ¼ (FOR 4 INCH STORZ)	1	A1297
	CUP SEAL 5.25 X 4.75 X ¼	1	A1296
3	BALL 7/16" STAINLESS (FOR LOCKED OUT COUPLINGS)	1	VB.437
4	PORT PLUG	1	A1299
5	LOCKING LEVER	1	A4171
6	SPRING TORSION	1	A4230
7	4" STORZ FITTING (USES A4730 ADAPTER ON NON ELBOWED GATE VALVES)	1	A4124
	5" STORZ FITTING	1	A4125
	6" STORZ FITTING	1	A4126
8	4" STORZ GASKET PRESSURE ONLY	1	A4215
	4" STORZ GASKET PRESSURE/VACUUM	1	A4216
	5" STORZ GASKET PRESSURE ONLY	1	A4220
	5" STORZ GASKET PRESSURE/VACUUM	1	A4221
	6" STORZ GASKET PRESSURE ONLY	1	A4225
	6" STORZ GASKET PRESSURE/VACUUM	1	A4226

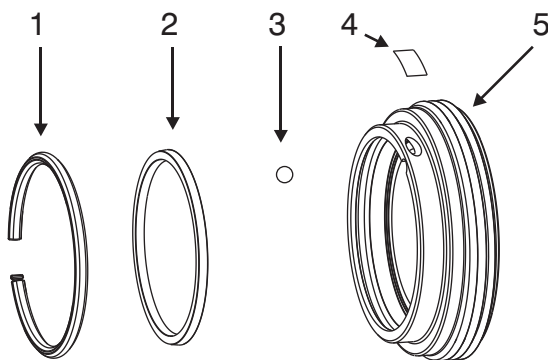

Table 4: Male Thread Spout Parts List

#	Part Description	Qty	Part #
1	PLASTIC STRIP 5.25"	1	A1291
2	CUP SEAL 5.25 X 4.75 X ¼	1	A1296
3	BALL 7/16" STAINLESS	1	VB.437
4	LABEL; PORT COVER	1	A1298
5	4.0" NH MALE SPOUT	1	A4620N
	4.5" NH MALE SPOUT	1	A4625N
	5.0" NH MALE SPOUT	1	A4630N
	6.0" NH MALE SPOUT	1	A4635N

7.0 DRAWINGS AND PARTS LISTS

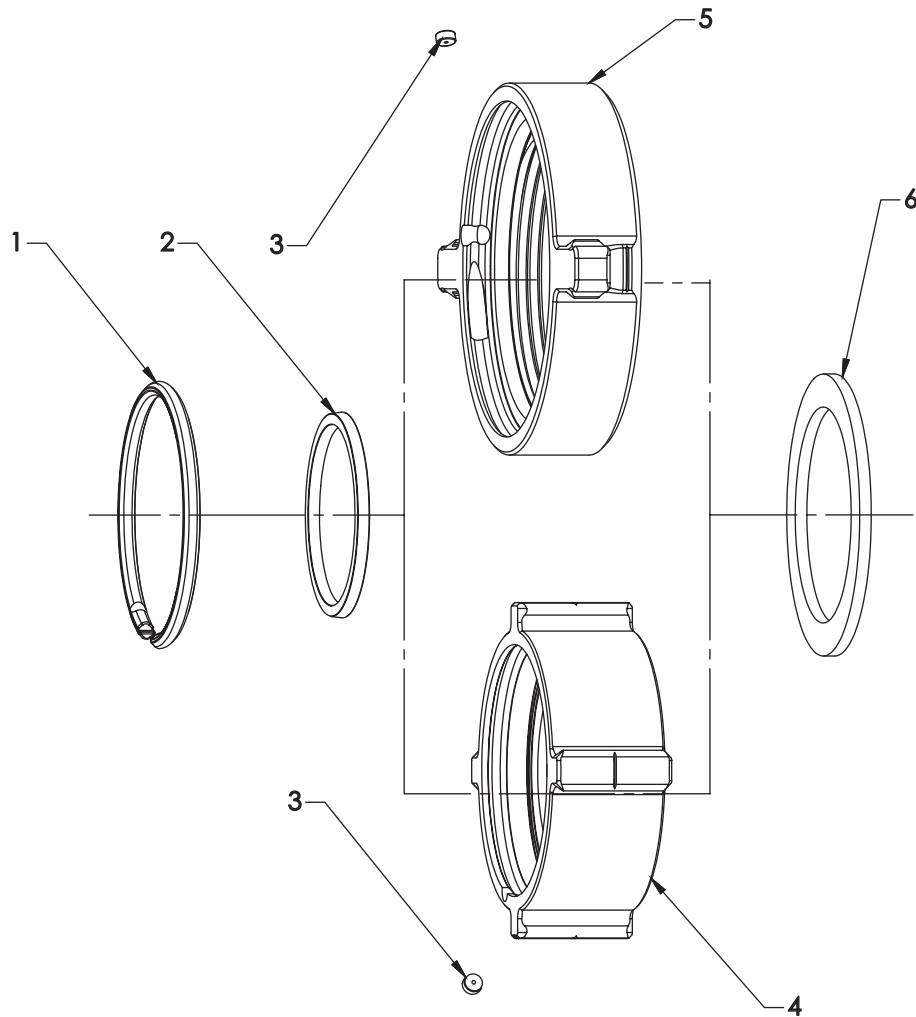

Table 5: Female Thread Coupling Parts List

#	Part Description	Qty	Part #
1	PLASTIC STRIP 5.25"	1	A1291
	PLASTIC STRIP 7.00" (FOR 6.0" FEMALE THREADED COUPLINGS)	1	A1290
2	CUP SEAL 5.25 (FOR 4.0" THRU 5.0" COUPLINGS ONLY)	1	A1296
3	PORT PLUG	1	A1299
4	4.0" NH FEMALE ROCKERLUG COUPLING	1	A4660N
	4.5" NH FEMALE ROCKERLUG COUPLING	1	A4665N
	5.0" NH FEMALE ROCKERLUG COUPLING	1	A4670N
	6.0" NH FEMALE (USES A4745 ADAPTER ON NON ELBOWED GATE VALVES)	1	A1266NX
5	4.0" NH FEMALE HANDLE COUPLING	1	A4560N
	4.5" NH FEMALE HANDLE COUPLING	1	A4565N
	5.0" NH FEMALE HANDLE COUPLING	1	A1261NT
	6.0" NH FEMALE (USES A4745 ADAPTER ON NON ELBOWED GATE VALVES)	1	A1266NX
6	4.0" HOSE COUPLING GASKET	1	V3198
	4.5" HOSE COUPLING GASKET	1	V3210
	5.0" HOSE COUPLING GASKET	1	V3220
	6.0" HOSE COUPLING GASKET	1	V3240

7.0 DRAWINGS AND PARTS LISTS

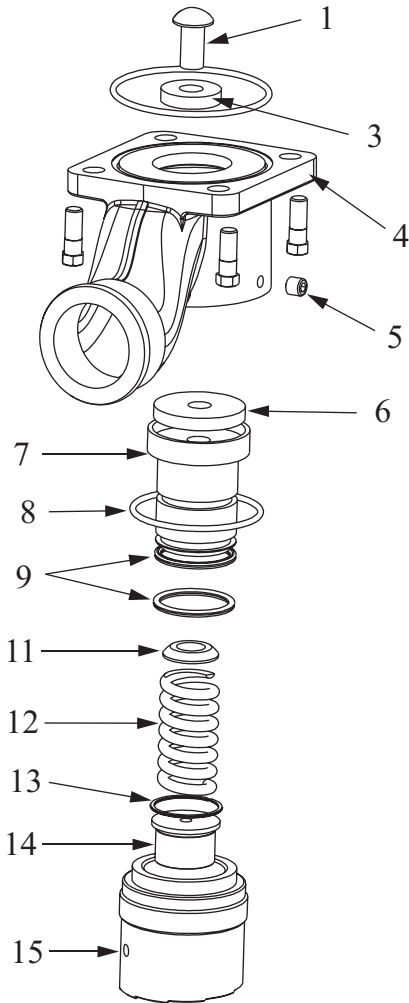

Table 6: Relief Valve Parts List

Index	Description	QTY	Part #
1	1/2-13 X 1.0 BUTTON HEAD CAP SCREW	1	VT50-13BH1.0
3	DEBRIS WASHER	1	A1169
4	HOUSING W/OUT THDS	1	A1150
5	5/16-18 X 3/8 SOCKET SET SCREW CUP POINT	1	VT31-18SS375
6	VALVE SEAT	1	A1168
7	PISTON -HARDCOAT	1	A1160
8	O-RING-232 2-3/4 ID 1/8 C/S	1	VO-232
9	QUAD RING 422 1.5 ID X 1/8 C/S	2	VOQ-4222
11	SPRING SEAT	1	A1166
12	RELIEF SPRING	1	A1170
13	SMALLEY RING	1	V4210
14	ADJUSTING SCREW	1	A1167
15	SPRING HOUSING	1	A1164

8.0 MAINTENANCE

The valve should be disconnected, cleaned and visually inspected inside and out periodically. Moving parts such as hand wheels, gate/seat and couplings should be checked for smooth and free operation and greased as needed. A silicone based grease such as Dow Corning 112, or equivalent, will exclude moisture and retard the effects of corrosion. If valve becomes difficult to move under pressure, grease all four internal Blade Ramps in Gate Valve (see drawing for ramp locations).

Grease all four (4)
internal blade ramps.

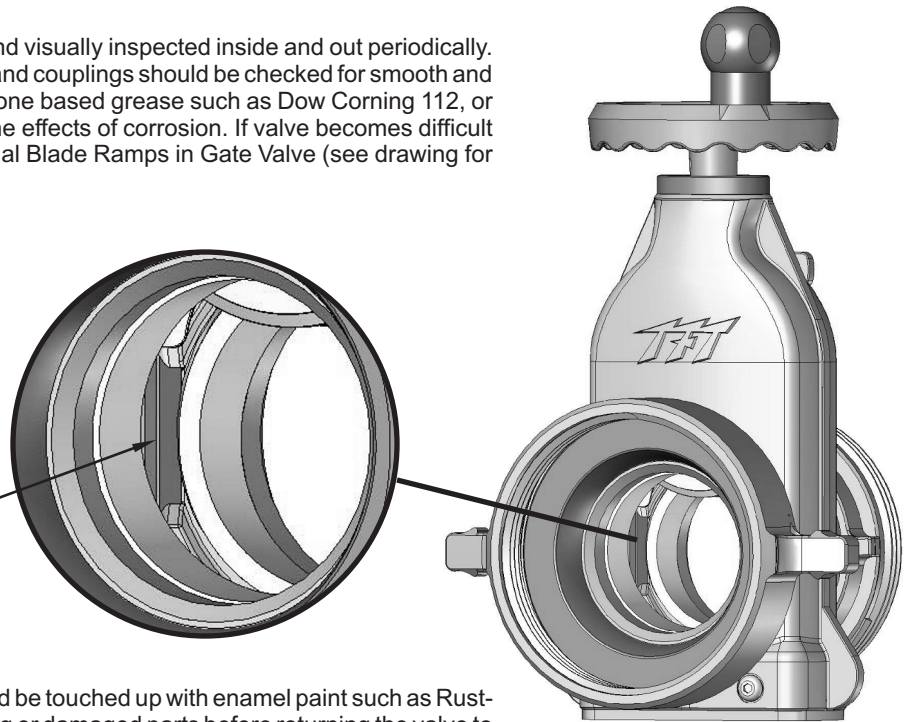

Any scrapes that expose bare aluminum should be touched up with enamel paint such as Rust-Oleum to inhibit corrosion. Replace any missing or damaged parts before returning the valve to service.

CAUTION

Dissimilar metals coupled together can cause galvanic corrosion that can result in the inability to unscrew the threads of complete loss of thread engagement over time. Per NFPA 1962 (1998 edition), if dissimilar metals are left coupled together an anti-corrosive lubricant should be applied to the threads. Also the coupling should be disconnected and inspected at least quarterly.

CAUTION

Any alterations to the Jumbo Gate Valve and its markings could diminish safety and constitutes a misuse of this product.

9.0 WARRANTY

Task Force Tips, Inc., 2800 East Evans Avenue, Valparaiso, Indiana 46383 ("TFT") warrants to the original purchaser of its Jumbo Gate Valve ("equipment"), and to anyone to whom it is transferred, that the equipment shall be free from defects in material and workmanship during the five (5) year period from the date of purchase.

TFT's obligation under this warranty is specifically limited to replacing or repairing the equipment (or its parts) which are shown by TFT's examination to be in a defective condition attributable to TFT. To qualify for this limited warranty, the claimant must return the equipment to TFT, at 2800 East Evans Avenue, Valparaiso, Indiana 46383, within a reasonable time after discovery of the defect. TFT will examine the equipment. If TFT determines that there is a defect attributable to it, TFT will correct the problem within a reasonable time. If the equipment is covered by this limited warranty, TFT will assume the expenses of repair.

If any defect attributable to TFT under this limited warranty cannot be reasonably cured by repair or replacement, TFT may elect to refund the purchase price of the equipment, less reasonable depreciation, in complete discharge of its obligations under this limited warranty. If TFT makes this election, claimant shall return the equipment to TFT free and clear of any liens and encumbrances.

This is a limited warranty. The original purchaser of the equipment, any person to whom it is transferred, and any person who is an intended or unintended beneficiary of the equipment, shall not be entitled to recover from TFT any consequential or incidental damages for injury to person and/or property resulting from any defective equipment manufactured or assembled by TFT. It is agreed and understood that the price stated for the equipment is in part consideration for limiting TFT's liability. Some states do not allow the exclusion or limitation of incidental or consequential damages, so the above may not apply to you.

TFT shall have no obligation under this limited warranty if the equipment is, or has been, misused or neglected (including failure to provide reasonable maintenance) or if there have been accidents to the equipment or if it has been repaired or altered by someone else.

THIS IS A LIMITED EXPRESS WARRANTY ONLY. TFT EXPRESSLY DISCLAIMS WITH RESPECT TO THE EQUIPMENT ALL IMPLIED WARRANTIES OF MERCHANTABILITY AND ALL IMPLIED WARRANTIES OF FITNESS FOR A PARTICULAR PURPOSE. THERE IS NO WARRANTY OF ANY NATURE MADE BY TFT BEYOND THAT STATED IN THIS DOCUMENT.

This limited warranty gives you specific legal rights, and you may also have other rights which vary from state to state.

TASK FORCE TIPS, Inc.
Made in USA • www.tft.com

2800 E Evans Ave • Valparaiso , IN 46383-6940 USA
800-348-2686 • 219-462-6161 • Fax 219-464-7155