

INSTRUCTIONS FOR SAFE OPERATION AND MAINTENANCE

This instruction manual is intended to familiarize firefighters and maintenance personnel with the operation, servicing, and safety procedures associated with the PROTECTOR Station Monitor. This manual should be kept available to all operating and maintenance personnel.

⚠ WARNING

Read instruction manual before use. Operation of this device without understanding the manual and receiving proper training is a misuse of this equipment. A person who has not read and understood all operating and safety instructions is not qualified to operate the PROTECTOR Station Monitor.

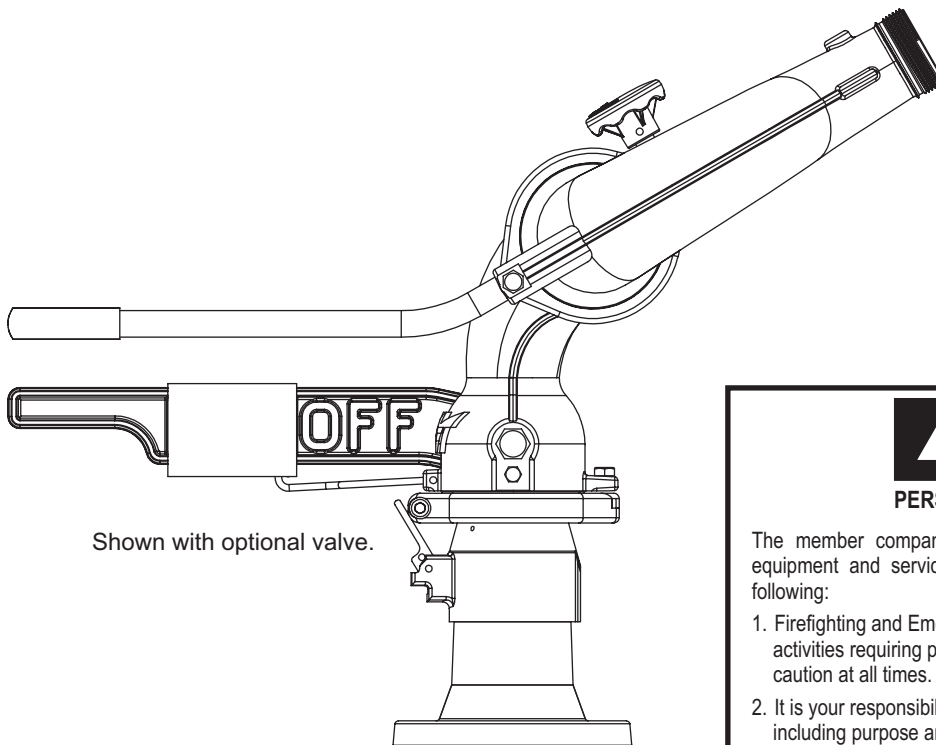

Shown with optional valve.

Maximum flow is
1250 GPM
(4800 L/MIN)

Maximum inlet pressure is
250 PSI (17 BAR)

⚠ DANGER

PERSONAL RESPONSIBILITY CODE

The member companies of FEMSA that provide emergency response equipment and services want responders to know and understand the following:

1. Firefighting and Emergency Response are inherently dangerous activities requiring proper training in their hazards and the use of extreme caution at all times.
2. It is your responsibility to read and understand any user's instructions, including purpose and limitations, provided with any piece of equipment you may be called upon to use.
3. It is your responsibility to know that you have been properly trained in Firefighting and /or Emergency Response and in the use, precautions, and care of any equipment you may be called upon to use.
4. It is your responsibility to be in proper physical condition and to maintain the personal skill level required to operate any equipment you may be called upon to use.
5. It is your responsibility to know that your equipment is in operable condition and has been maintained in accordance with the manufacturer's instructions.
6. Failure to follow these guidelines may result in death, burns or other severe injury.



Fire and Emergency Manufacturers and Services Association, Inc.
P.O. Box 147, Lynnfield, MA 01940 • www.FEMSA.org

TABLE OF CONTENTS

1.0 MEANING OF SIGNAL WORDS

2.0 GENERAL INFORMATION

2.1 STYLES AND OPTIONS

2.2 PART IDENTIFICATION

2.3 OVERALL DIMENSIONS

3.0 INSTALLATION

3.1 FLANGE SIZES

3.2 GENERAL MOUNTING

3.3 BOLTED FLANGE JOINT

3.4 WATER SUPPLY

3.5 NOZZLE FOR THREADED EXIT

3.6 PORT FOR DRAIN VALVE

3.7 PORT FOR PRESSURE GAUGE

4.0 PRESSURE LOSS

4.1 VALVE OPERATION

4.2 SIDE TO SIDE ROTATION AND ROTATION LOCK

4.3 ELEVATION CONTROL AND ELEVATION LOCK

5.0 MAINTENANCE AND REPAIRS

5.1 LOWER SWIVEL SEAL AND VALVE SEAT

5.2 UPPER SWIVEL SEAL AND SWIVEL INSERTS

6.0 DRAWINGS AND PARTS LIST

7.0 WARRANTY

1.0 MEANING OF SIGNAL WORDS

A safety related message is identified by a safety alert symbol and a signal word to indicate the level of risk involved with a particular hazard. Per ANSI standard Z535.4-1998 the definitions of the three signal words are as follows:



DANGER indicates an imminently hazardous situation which, if not avoided, will result in death or serious injury.



WARNING indicates a potentially hazardous situation which, if not avoided, could result in death or serious injury.



CAUTION indicates a potentially hazardous situation which, if not avoided, may result in minor or moderate injury.

2.0 GENERAL INFORMATION



This equipment is intended for use by trained personnel for firefighting. Its use for other purposes may involve hazards not addressed by this manual. Seek appropriate guidance and training to reduce risk of injury.

The Task Force Tips' Protector is a simple and rugged fixed station monitor with many unique features. Its patented waterway gives low friction loss and delivers water to the nozzle with fewer twists and turns than a conventional monitor. The optional built-in on/off valve with position indicator eliminates the need to add a costly valve to the monitor installation. The Protector is capable of flowing up to 1250 gpm (4500 l/min) while maintaining a FULL 360° rotational ability. The lever-action rotational lock is activated in one motion, visually confirmed, and securely holds the monitor's horizontal position. The Protector can be directly bolted to many common pipe flanges. The outlet is available with various 2.5" (65mm) male threads. The simple and basic design requires no grease application or other maintenance. Swiveling elements and seals (including valve seat) can be replaced within a few minutes with common hand tools. Threaded ports (0.25" NPT) (6mm) are provided for drain valve and pressure gauge installation. Maximum pressure is 250 psi (17 bar). The Protector is hardcoat anodized ANSI 356-T6 aluminum and is fully powder coat finished inside and out. Swivel clamps, 3" (75mm) valve ball, trunnions, and hardware are 18-8 stainless steel.

2.1 STYLES AND OPTIONS

The Protector station monitor comes in four basic styles as shown in the figures below:

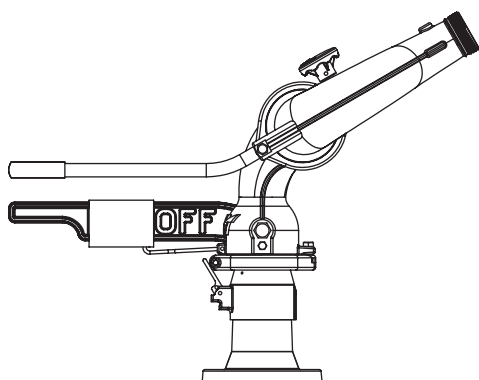

FIG 2.1A Valve with Threaded Exit

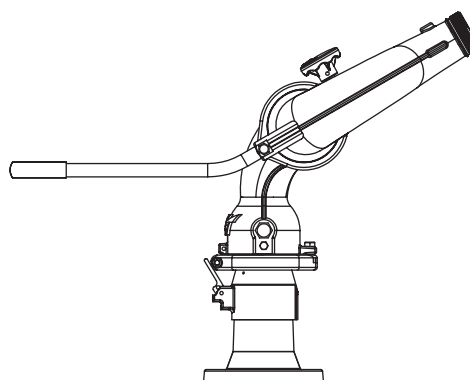

FIG 2.1B No Valve with Threaded Exit

2.2 PART IDENTIFICATION

Figure 2.2 shows a Protector monitor with "Valve and Threaded Exit" and identifies the various parts and controls.

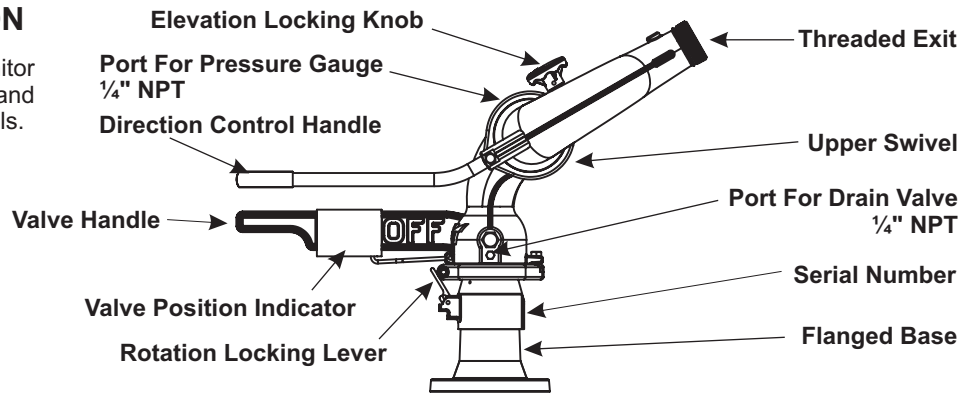
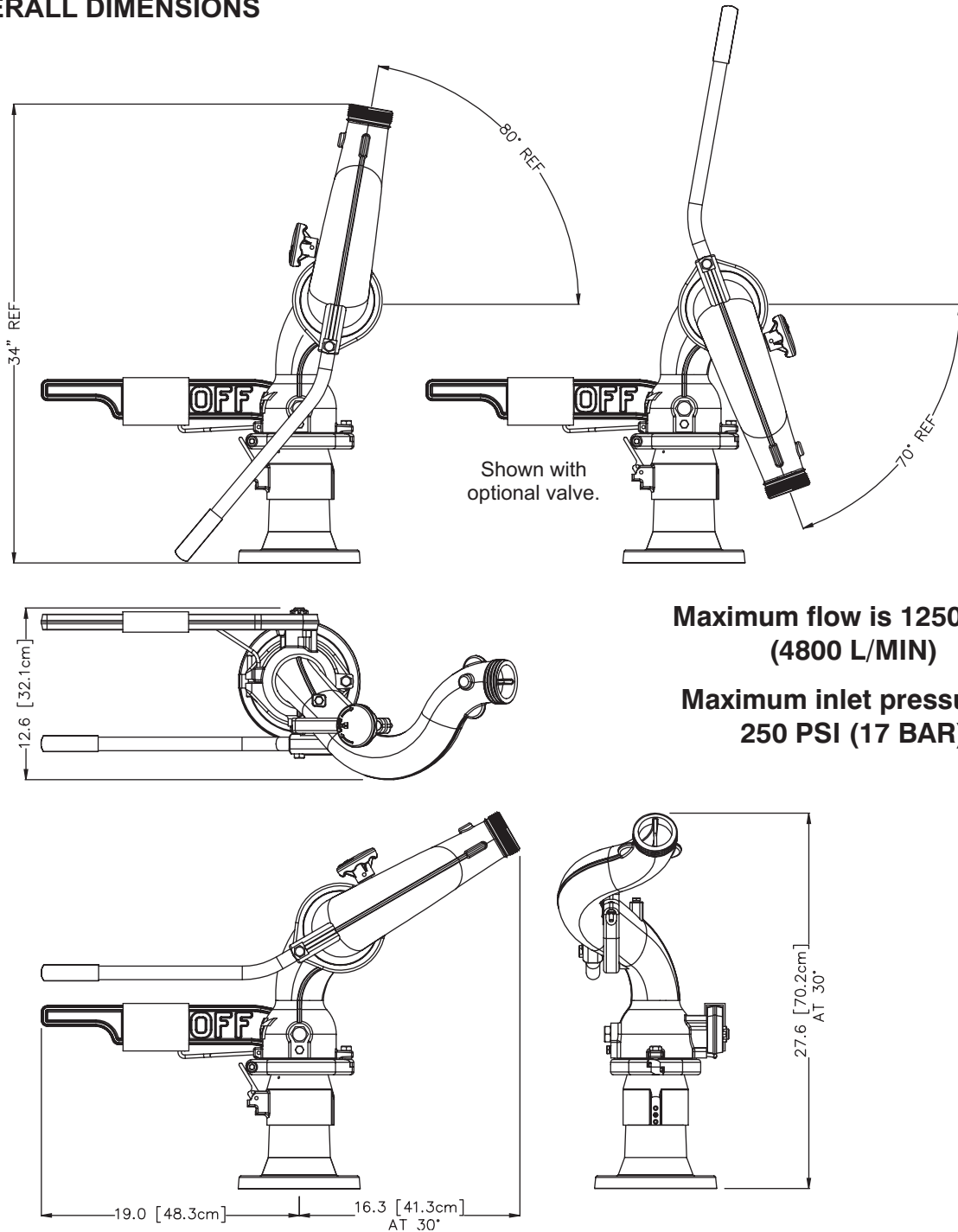

FIG 2.2 Protector Monitor Parts

2.3 OVERALL DIMENSIONS



**Maximum flow is 1250 GPM
(4800 L/MIN)**

**Maximum inlet pressure is
250 PSI (17 BAR)**

FIG 2.3 Overall Dimensions

3.0 INSTALLATION

3.1 FLANGE SIZES

The table below gives the available flange designations and actual sizes. The designation is marked on the outer diameter of the flange.

FITS FLANGE	OUTSIDE DIAMETER	THICKNESS	BOLT HOLE CIRCLE	NUMBER OF BOLTS	SIZE OF BOLTS	TORQUE ON BOLTS
3" ANSI 125/150	7.50"	0.75"	6.00"	4	5/8"	76-80 FT-LBS
4" ANSI 150	9.00"	0.94"	7.50"	8	5/8"	76-80 FT-LBS
DN80 PN16	200 mm	22 mm	160 mm	8	16 mm	100-107 NEWTON-METER
DN100 PN16	220 mm	22 mm	180 mm	8	16 mm	100-107 NEWTON-METER

3.2 GENERAL MOUNTING

The Protector station monitor is installed to a riser pipe by a bolted flange joint. Check that no interference exists between the Protector and surrounding hardware that would limit its usefulness. If a valve is to be mounted under the Protector, check that no interference exists with the valve handle. If a butterfly valve is to be mounted under the Protector, check that no interference exists between the butterfly and the flanged base of the Protector when the valve is in its open position.

3.3 BOLTED FLANGE JOINT

The use of flat faced flanges (without raised face) and full face gasket is recommended. Bolts should meet the requirements of high strength or intermediate strength bolting as defined in ASME B16.5-1996 sections 5.3.1 and 5.3.2. The flanged connection and gasket must withstand the internal pressure as well as shear and bending due to the nozzle reaction. Use a full face gasket per ASME 16.21-1992 or ISO 7483. Nozzle reaction can be as high as 1050 lbs (480kg) (1250 gpm at 250 psi) which would give a 1660 ft-lb bending moment at the flange joint (1050 lbs times 1.58ft). The tightening sequence of the bolts is shown in figure 3.3

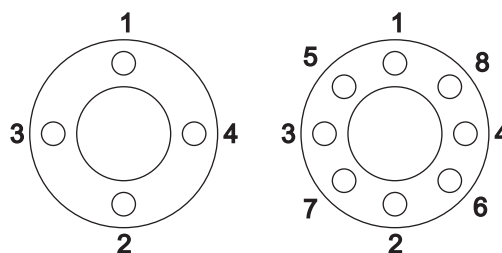

Tighten sequentially each bolt three times.

FIG 3.3 Flange Bolt Tightening Sequence

WARNING

Injury can occur from an inadequately supported monitor. The mounting must be capable of supporting the nozzle reaction force which can be as high as 950 lbs. This monitor is not intended for portable use. Flanges and pipe made from plastic are inadequate for monitor mounting and must not be used.

3.4 WATER SUPPLY

The Protector (or any monitor) must have an adequate supply of water and pressure to be effective. Make sure that pump(s) and water supply are sufficient and reliable. See section 4.0 for Protector pressure loss. Use with salt water or brackish water will shorten the service life of any product due to corrosion.

DANGER

An inadequate supply of pressure and/or flow will cause an ineffective stream and can result in injury, death or loss of property.

3.5 NOZZLE FOR THREADED EXIT

The Protector is available with 2.5 inch male threads (NH, BSP, or NPSH) for attachment of a nozzle. Greasing of threads before screwing on nozzle will reduce the chance of corrosion.

CAUTION

Nozzle threads must match threads on the Protector. Mismatched or damaged threads may cause nozzle to leak or uncouple under pressure and could cause injury.

CAUTION

Do not couple aluminum to brass. Dissimilar metals coupled together can cause galvanic corrosion that can result in inability to unscrew the threads or complete loss of thread engagement.

3.6 PORT FOR DRAIN VALVE

The Protector has a 1/4" female NPT threaded port for installation of a drain valve. This port is located just above the lower swivel and is shipped from the factory with a pipe plug installed. A drain valve is required in environments, which will reach temperatures below freezing to eliminate the risk of ice forming in the Bell Casting. The Protector may become damaged if ice is allowed to form in the Bell Casting.

3.7 PORT FOR PRESSURE GAUGE

The Protector has a 1/4" female NPT threaded port for installation of a pressure gauge if desired. This port is located by the upper swivel and is shipped from the factory with a pipe plug installed. If a pressure gauge is installed, check that no interference exists between the gauge and the upper swivel locking knob.

4.0 PRESSURE LOSS

Figure 4.0 gives a graph of pressure loss through the Protector station monitor.

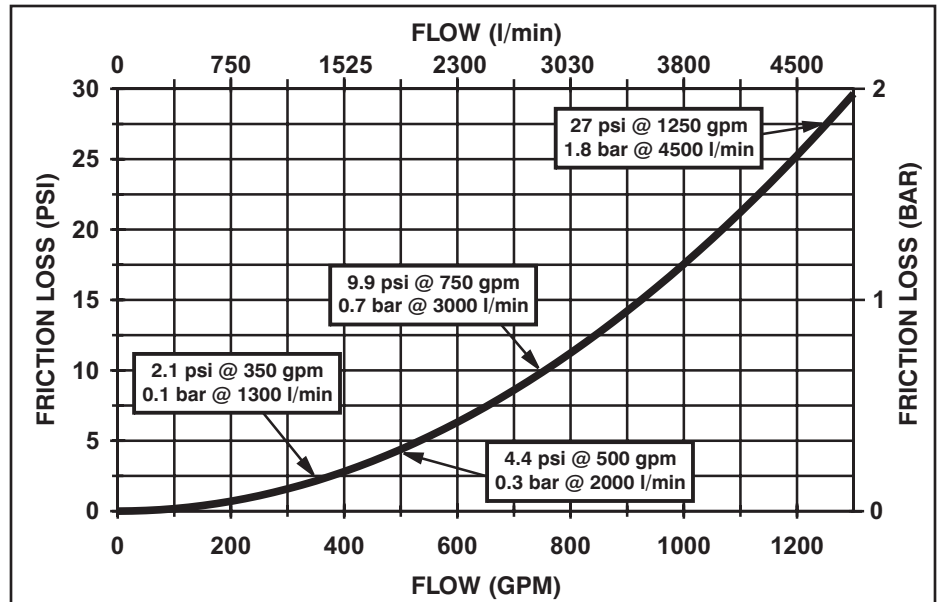

FIG 4.0
Protector Station Monitor
Pressure Loss

4.1 VALVE OPERATION

In models equipped with a built-in valve, the flow is OFF when the valve handle is horizontal and ON when the handle is vertical. Parts are manufactured so that the valve cannot be assembled out of phase. A position indicator shows the valves position as "OFF" or "ON". The position that the valve is normally left in will depend upon your particular location's standard operating procedure. Operate the valve slowly to reduce water hammer.

4.2 SIDE TO SIDE ROTATION AND ROTATION LOCK

The Protector can rotate from side to side on its swivel base (azimuth control). Lift the rotation lock lever and rotate the monitor right or left using the directional control handle (see figure 4.2). To lock the monitor in position, depress the rotation lock lever. A small spring holds the rotation lock lever in the unlocked position when it is disengaged. When the monitor is not in use, the rotation lock lever should be kept in the locked position.

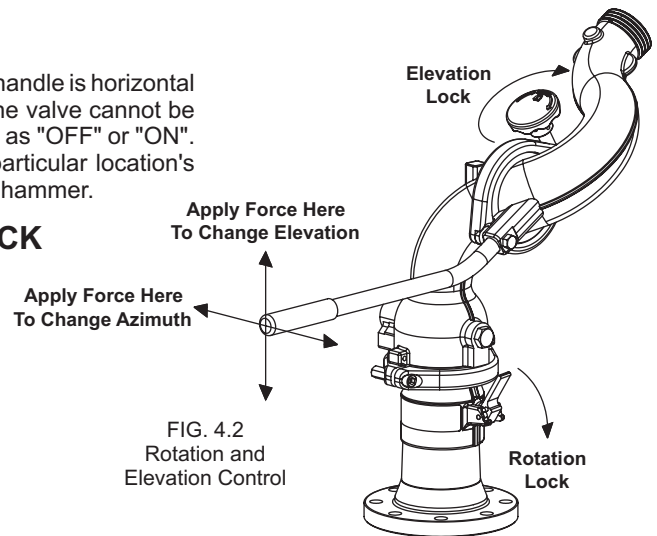

4.3 ELEVATION CONTROL AND ROTATION LOCK

The up and down direction (elevation) of the stream is changed by pushing or pulling vertically on the **direction control handle** (see figure 4.2). Twisting the **elevation locking knob** clockwise will increase the drag on the **upper swivel joint** to "lock" the monitor at a particular elevation. Select discharge devices that do not exceed the 70 ft-lb locking capability of the elevation lock.



Master stream flows are very powerful and capable of causing injury and property damage. Make sure the monitor is pointing in a safe direction before water to the monitor is turned on. Use care in directing the stream.



Care must be taken when loosening elevation locking knob so nozzle does not swing down quickly. Keep one hand on direction control handle while loosening elevation control knob. Be prepared to exert force on direction control handle as knob is loosened.



When pressure is released, nozzle will swing down if locking knob is not adequately tightened.

5.0 MAINTENANCE AND REPAIRS

The Protector Station monitor requires no routine maintenance. All seals slide on plastic surfaces and require no periodic greasing. The swiveling joints use plastic sliding elements that also do not require grease. The Protector should be inspected annually and after each use. In particular, check that:

- There are no leaks with valve off and while flowing.
- Valve handle moves freely between open and closed positions.
- Valve handle position indicator is functioning properly ('OFF' when horizontal, 'ON' when vertical).
- Swivels rotate while flowing at expected pressure and flow.
- Locking knobs loosen and tighten sufficiently.
- Nozzle is free of debris.

5.1 LOWER SEAL AND VALVE SEAT

If the lower joint leaks externally, or the valve does not fully shut off, then the lower seal and/or valve seat may need to be replaced. To replace these parts:

- Turn off water.
- Remove coupling nut from lower clamp using 5/8" wrench or socket.
- Remove socket head cap screw from lower clamp using 3/8" male hex wrench.
- Separate the joint by pivoting the clamp piece off of the flanged section.
- Pull out the valve seat and lower seal.
- Clean away dirt on flanges and clamps.
- Inspect seal and sealing surfaces of valve seat and flange.
- Replace damaged parts as needed.
- Apply grease to surface of seal.
- Snap black seal into groove on white valve seat.
- Insert assembly into monitor, white end first.
- Reassemble joint.
- Torque socket head cap screw to 50 ft-lbs prior to installing coupling nut.
- Torque coupling nut to 50 ft-lbs while preventing socket head cap screw from rotating.

5.2 UPPER SWIVEL SEAL AND SWIVEL INSERTS

If the upper swivel leaks or requires excessive force to swivel, then the upper swivel seal and/or plastic swivel inserts may need to be replaced. To replace these parts:

- Turn off water.
- Remove the cotter pin and then the nut on the locking knob with a 1/2 inch (13mm) socket.
- Remove the locking knob.
- Separate the joint by pivoting the clamp piece off of the flanged section.
- Pry out the swivel inserts and inspect for damage.
- Clean away dirt on flanges and clamps.
- Inspect the seal and sealing surface of the flange.
- Replace damaged parts as needed.
- Apply grease to surface of seal.
- Reassemble joint.

6.0 DRAWINGS AND PARTS LIST

REF #	PART #	QTY.	DESCRIPTION
1	Z285	1	Slide
2	VP156X1.5	1	5/32 x 1 1/2 Cotter Pin 18-8 SS
3	VT75-10SF	1	3/4 -10 Slot Fin Hex Nut
4	VW1.5X81-134	1	3/4 Stainless Washer
5	Z280	1	Valve Handle
6	V4235	1	VS-118-S02 Smalley Ring
7	VM4900	1	Belleville Spring
8	VO-214	1	O-Ring-214
9	Z265	1	Trunnion
11	VFHP2M	2	1/4" Hex Head Plug
12	Z221	2	Clamp
13	Z240	1	Lock Bolt
14	VP250X1.375H	1	1/4 x 1 3/8 HDP Spiral Pin, Rotational Lock Stop Pin
15	Z245	1	Lock Knob
16	Z225	4	Swivel Insert
17	Z230	1	Upper Swivel Seal
18	Z220	2	Clamp Threaded
19	VT31-18SLNT	1	5/16-18 Castle Nut
20	VP063X.50	1	1/16 x 1/2 Cotter Pin
28	VT50-13HX2.7	1	1/2-13 x 2 3/4 Hex Bolt Fully Threaded
29	Z316	1	Elevation Handle Nut
30	VO-016	1	O-Ring-016
31	Z315	1	Elevation Handle
32	Z260	1	Trunnion
33	VT50-13HX1.7	1	1/2-13 x 1 3/4 Hex Bolt Fully Threaded
34	Z250	1	Valve Ball

REF #	PART #	QTY.	DESCRIPTION
35	Z270	1	Rear Valve Seat
36	Z275	1	Lower Seal
40	Z286	1	Slide Link
41	Z261	1	Plug
43	X752	1	2.5" Clapper Washer
44	VT25-28BH500	1	1/4 -28 x 1/2 Button Head Cap Screw
45	Z317	1	Handle Grip
50	Z425	1	Industrial Bell with Rim
51	X170	1	Rotation Lock Insert
52	Z152	1	Rotation Lock Spring
53	X160	1	Rotation Lock Lever
54	X180	1	Rotation Lock Pivot
55	X137	1	Pin Retainer
56	ZL101	1	Name Label - Protector
	ZL101-F		Name Label - Petrojet
57	ZL102	1	Serialized Label - Protector & Petrojet
58	A1303	1	Model Number Label
60	X120	1	Wear Strip
61	X125	1	Cup Seal
62	VB.312	76	5/16" Ball 302SS
63	VT37-24SS375	2	3/8-24 X 3/8" Set Screw
64	VT25-28ZERK	1	1/4-28 Grease Zerk
65	VT50-13SH2.5	1	1/2-13 X 2.5 Socket Head Cap Screw 18-8 SS
66	VT50-13CPLNT	1	1-2-13 X 1-1/4 Coupling Nut 18-8 SS
67	VR4290	1	1/4" Self Locking Ring
68	VW500x265-63	1	1/4" S.S. Washer

6.0 DRAWINGS AND PARTS LIST

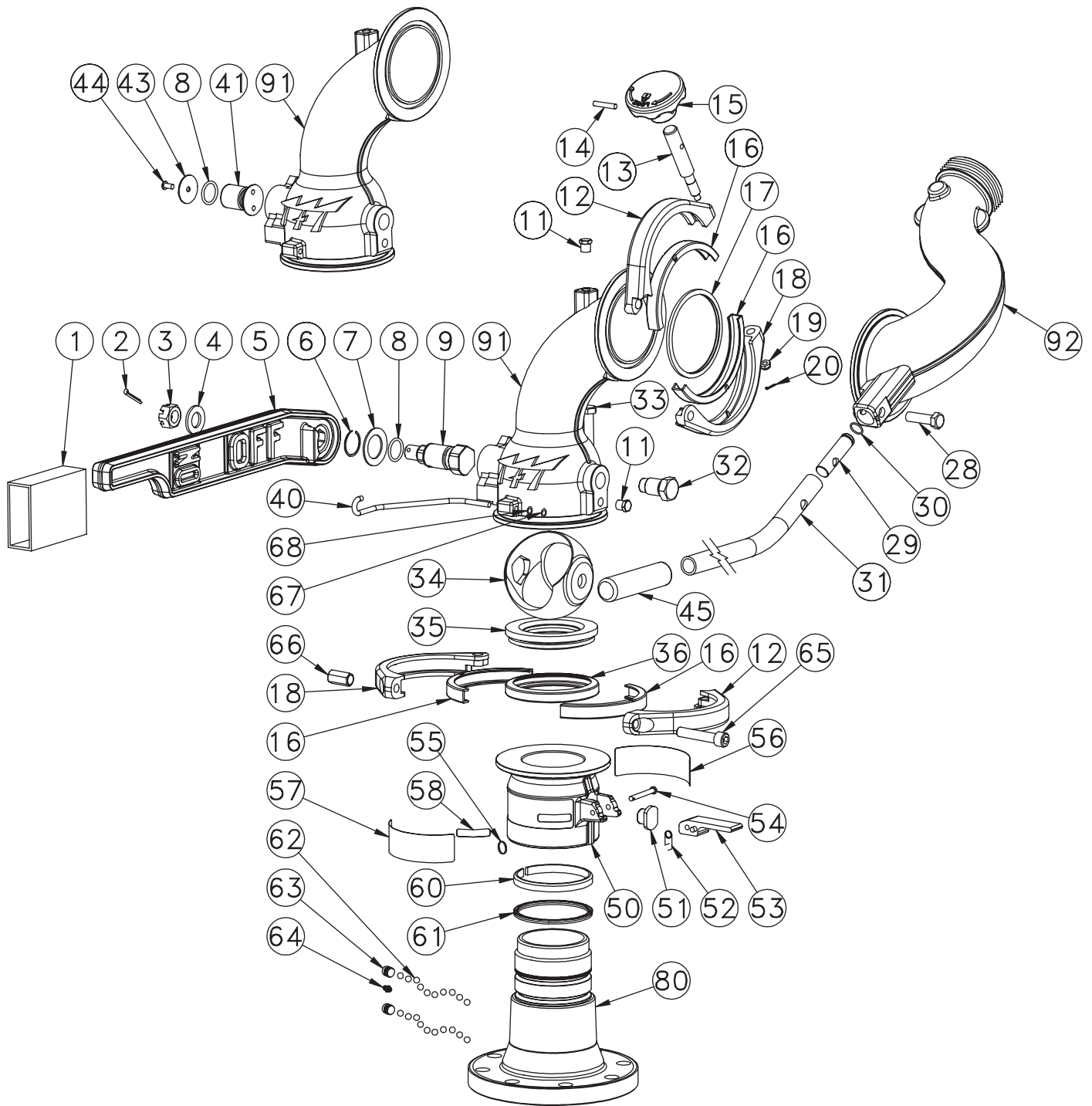

REF#	ALUMINUM PART #	QTY.	DESCRIPTION
80	X410-3ASA	1	3" ANSI 150
	X414-4ASA		4" ANSI 150
	X423		DN80, PN16
	X424		DN100, PN16
91	Z210A	1	Bell
92	Z310ABJ	1	Exit, 2 ½ BSP
	Z310AIJ		Exit, 2 ½ NPSH
	Z310ANJ		Exit, 2 ½ NH

**NOTE: SPECIFY COLOR WHEN ORDERING
AMERICAN FIRE ENGINE RED OR RAL 3000**

7.0 WARRANTY

Task Force Tips, Inc., 2800 East Evans Avenue, Valparaiso, Indiana 46383-6940 USA ("TFT") warrants to the original purchaser of its Protector Station Monitor and other equipment ("equipment"), and to anyone to whom it is transferred, that the equipment shall be free from defects in material and workmanship during the five (5) year period from the date of purchase.

TFT's obligation under this warranty is specifically limited to replacing or repairing the equipment (or its parts) which are shown by TFT's examination to be in a defective condition attributable to TFT. To qualify for this limited warranty, the claimant must return the equipment to TFT, at 2800 East Evans Avenue, Valparaiso, Indiana 46383-6940 USA, within a reasonable time after discovery of the defect. TFT will examine the equipment. If TFT determines that there is a defect attributable to it, it will correct the problem within a reasonable time. If the equipment is covered by this limited warranty, TFT will assume the expenses of repair.

If any defect attributable to TFT under this limited warranty cannot be reasonably cured by repair or replacement, TFT may elect to refund the purchase price of the equipment, less reasonable depreciation, in complete discharge of its obligations under this limited warranty. If TFT makes this election, claimant shall return the equipment to TFT free and clear of any liens and encumbrances.

This is a limited warranty. The original purchaser of the equipment, any person to whom it is transferred, and any person who is an intended or unintended beneficiary of the equipment, shall not be entitled to recover from TFT any consequential or incidental damages for injury to person and/or property resulting from any defective equipment manufactured or assembled by TFT. It is agreed and understood that the price stated for the equipment is in part consideration for limiting TFT's liability. Some states do not allow the exclusion or limitation of incidental or consequential damages, so the above may not apply to you.

TFT shall have no obligation under this limited warranty if the equipment is, or has been, misused or neglected (including failure to provide reasonable maintenance) or if there have been accidents to the equipment or if it has been repaired or altered by someone else.

THIS IS A LIMITED EXPRESS WARRANTY ONLY. TFT EXPRESSLY DISCLAIMS WITH RESPECT TO THE EQUIPMENT ALL IMPLIED WARRANTIES OF MERCHANTABILITY AND ALL IMPLIED WARRANTIES OF FITNESS FOR A PARTICULAR PURPOSE. THERE IS NO WARRANTY OF ANY NATURE MADE BY TFT BEYOND THAT STATED IN THE DOCUMENT.

This limited warranty gives you specific legal rights, and you may also have other rights which vary from state to state.

TASK FORCE TIPS, Inc.
MADE IN USA • www.tft.com

2800 E Evans Ave, Valparaiso, IN 46383-6940 USA
800-348-2686 • 219-462-6161 • Fax 219-464-7155