

RANGE AND TRAJECTORY DATA OF HAND HELD NOZZLES

Jet range testing of hand held nozzles was conducted on 2 August, 1994 at LTV Steel Works of East Chicago, Indiana U.S.A.. This document presents the results of that testing. All range testing was done inside a building to assure that data taken was for still air conditions. The test was conducted according to the methods specified in Norme Francaise NF S61-820. Test set-up is shown below.

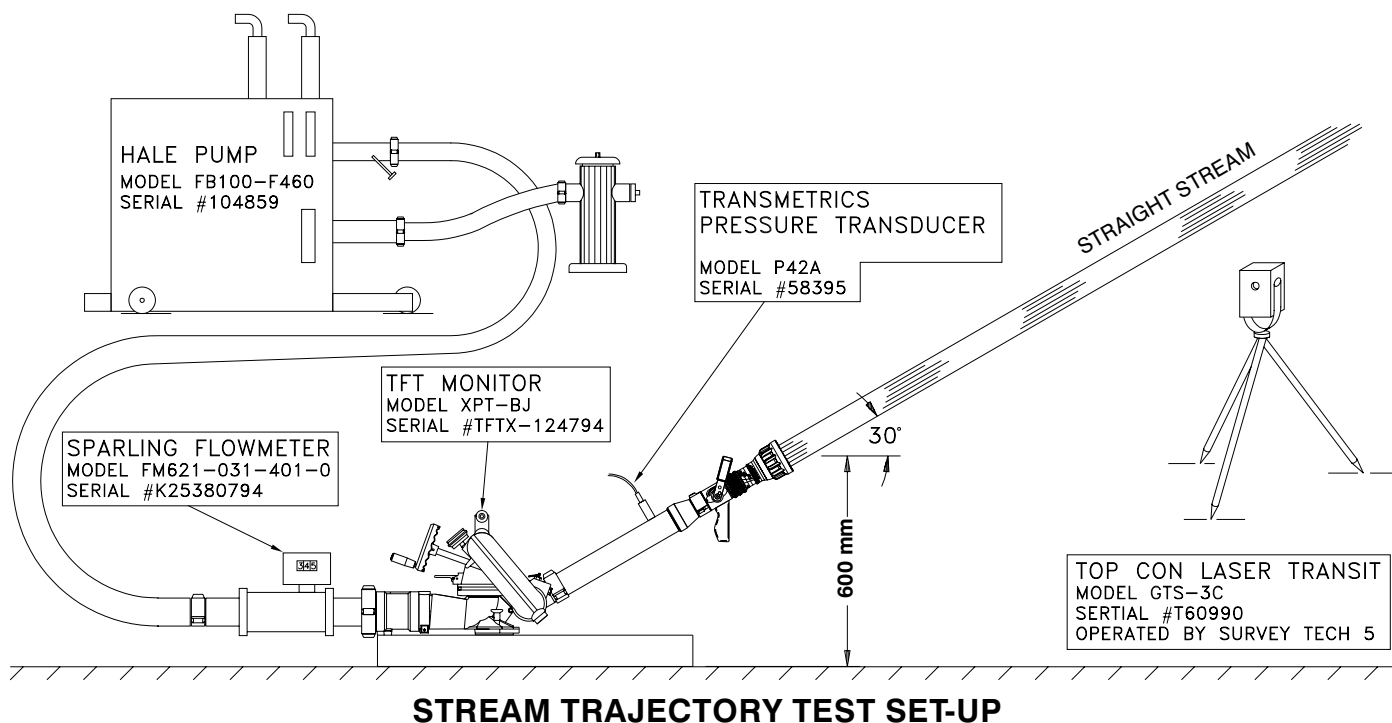

TEST PROCEDURE A fire fighting monitor was fastened to the floor of the building to assure a stable base for the nozzle. Nozzle elevation angle was set with a digital angle gage (Wedge Innovations, Series 200) to 30 degrees. Nozzle flow was monitored using a magnetic flow meter and a digital pitot pressure transducer at the nozzle inlet. Both devices were calibrated previously to within a maximum error of 1% on an instrument traceable to the United States National Bureau of Standards. The pump was adjusted to obtain the desired flow. A surveyor from PTGR Engineers-Land Surveyors was hired to take horizontal and vertical distance measurements along the jet using a laser operated transit. Several points along each stream trajectory were recorded to an accuracy of within 5 centimeters. Data was taken for all Quadrafog nozzles for all flow settings at pressures of 4, 6 and 8 BAR. Automatic nozzles were tested at several different flows in standard and low pressure mode (if so equipped). Both distance to the furthest drops of water and to the effective fire fighting range were recorded.

TEST RESULTS Graphs of these results, representing the shape of the stream as it travels through the air in no wind conditions, are presented on the following pages.

ULTIMATIC SERIES STREAM TRAJECTORIES

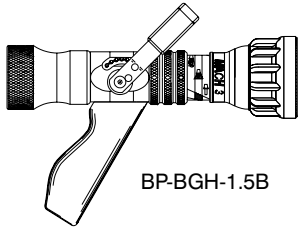

BP-BGH-1.5B

ULTIMATIC 6 bar

Flow range 38-380 l/min, automatic pressure control at 6.0 bar. DMR A 5/14

NOZZLE TESTED

ULTIMATIC 6 bar
Model: BP-BGH-1.5B
Serial #: TFTB-106976

6.0 BAR ULTIMATIC

(Formerly rated at 5.4 bar)

CURVE	A	B	C	D
FLOW (L/MIN)	100	200	300	380
PRESSURE (BAR)	3.2	4.1	4.9	5.5
NOZZLE REACTION (KGF)	4	9	15	21

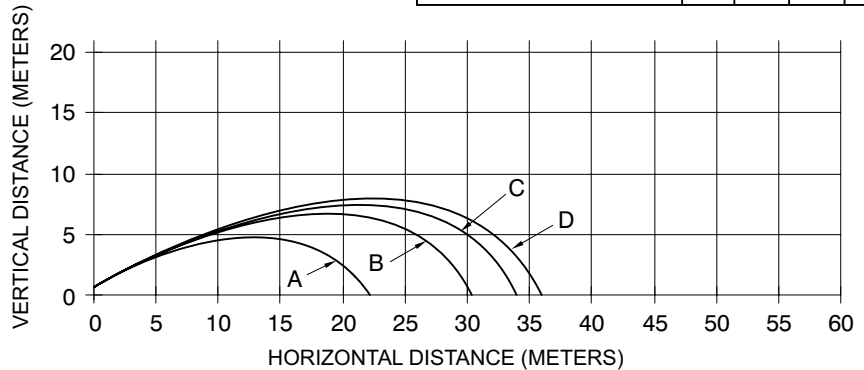

7 BAR ULTIMATIC

CURVE	A	B	C	D	E
FLOW (L/MIN)	100	200	300	400	500
PRESSURE (BAR)	4.9	5.8	6.5	7.8	8.7
NOZZLE REACTION (KGF)	5	11	18	26	34

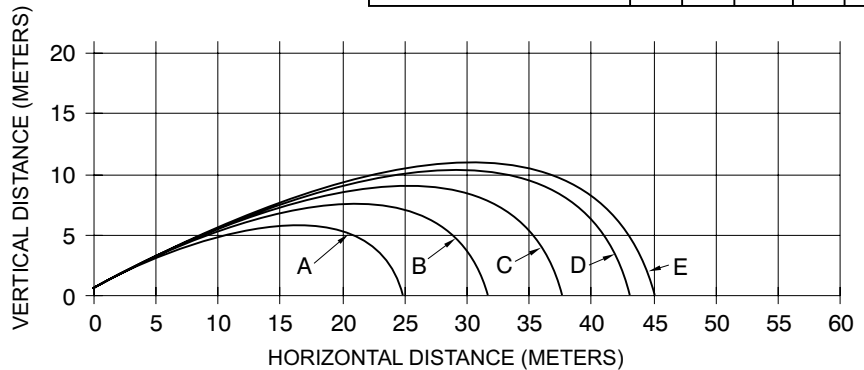

ULTIMATIC, 7 bar

Flow range 40-500 l/min, automatic pressure control at 7 bar.

NOZZLE TESTED

ULTIMATIC, 7 bar
Model: BP-BGH-1.5B
Serial #: TFTB-015741



TASK FORCE TIPS

Notes: Stream trajectories shown are for no wind conditions at 30 degree elevation. Wind can substantially alter the shape and reach of the stream of any nozzle. Effective fire fighting range of nozzles is shown. Maximum range of last water drop is approximately 10% farther.

MID-MATIC and Mid-Force STREAM TRAJECTORIES

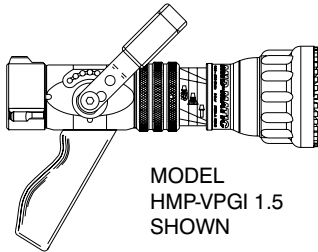

MID-MATIC

Flow range 100-600 l/min, automatic pressure control at 6 bar. DMR A 10/18

MID-FORCE

Flow range 100-600 l/min, automatic pressure control at 6 bar and emergency low pressure mode.

NOZZLE TESTED

Mid-Force
Model: HMP-VPGI 1.5
Serial #: TFTH-148580

MID-MATIC or MID-FORCE IN STANDARD 6 BAR PRESSURE MODE

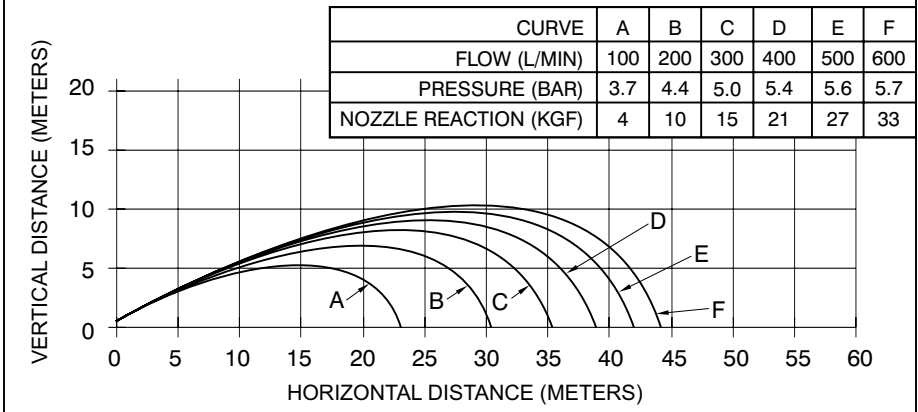

MID-FORCE IN LOW PRESSURE MODE

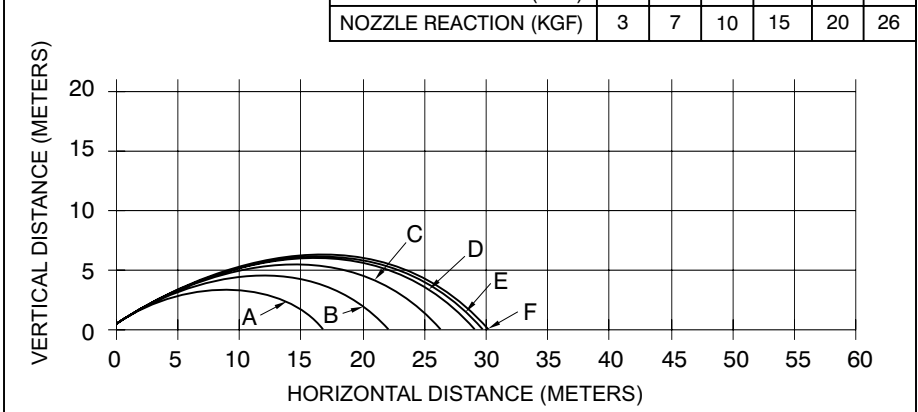

MID-FORCE

Flow range 100-600 l/min, automatic pressure control at 6 bar and emergency low pressure mode. DMR A 10/18

NOZZLE TESTED

Mid-Force
Model: HMDP-VPGI 1.5
Serial #: TFTH-148580



Notes: Stream trajectories shown are for no wind conditions at 30 degree elevation. Wind can substantially alter the shape and reach of the stream of any nozzle. Effective fire fighting range of nozzles is shown. Maximum range of last water drop is approximately 10% farther.

JETMATIC and DUO-JET STREAM TRAJECTORIES

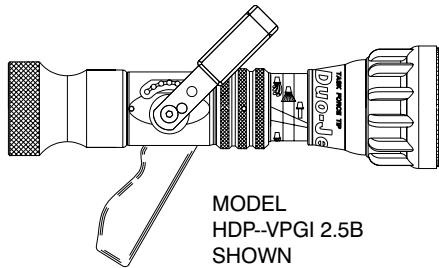

JETMATIC or DUO-JET 6 BAR IN STANDARD PRESSURE MODE

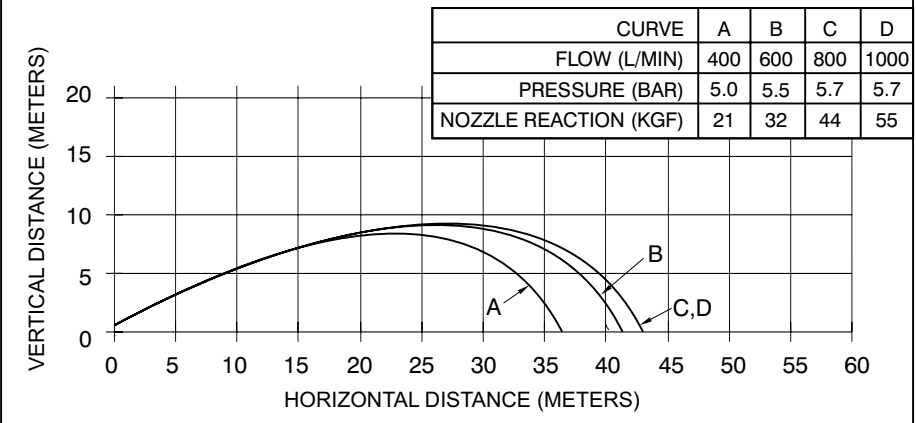

JETMATIC
Flow range 200-1000 L/MIN, automatic pressure control at 6 BAR. DMR A 12/25

DUO-JET
Flow range 200-1000 L/MIN, automatic pressure control with 6 BAR and emergency low pressure mode. DMR A 12/25

NOZZLE TESTED
DUO-JET
Model: HDP-VPGI 2.5B
Serial #: TFTH-101828

DUO-JET IN LOW PRESSURE MODE

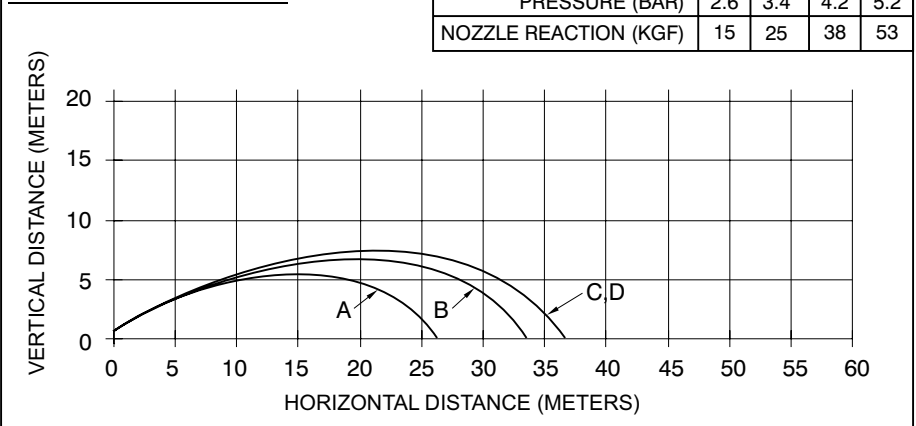

Jet-Matics and Duo-Jets produced before 1995 were rated at 6.8 bar. Reach, for a given flow, is approximately 10% longer. Consult manufacturer for data.



Notes: Stream trajectories shown are for no wind conditions at 30 degree elevation. Wind can substantially alter the shape and reach of the stream of any nozzle. Effective fire fighting range of nozzles is shown. Maximum range of last water drop is approximately 10% farther.

QUADRAFOG QF150 STREAM TRAJECTORIES

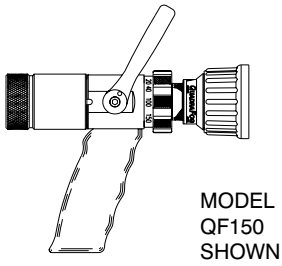

QF150 at 4 BAR

CURVE	A	B	C	D
SELECTOR RING SETTING	20	40	100	150
ACTUAL FLOW (L/MIN)	19	38	83	140
NOZZLE REACTION (KGF)	1	2	4	6

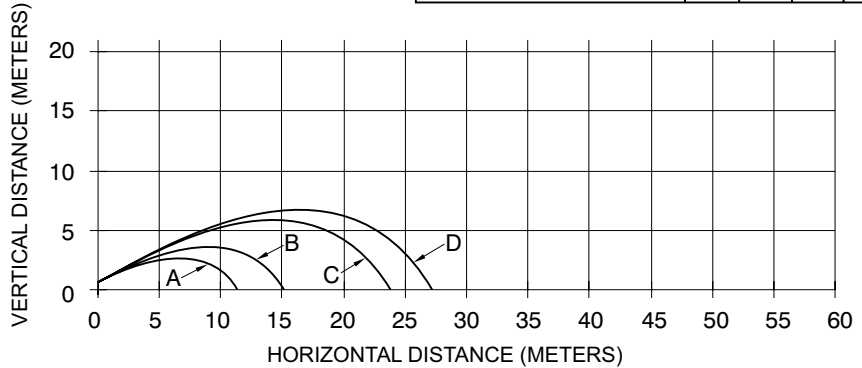

QF150 at 6 BAR

CURVE	A	B	C	D
SELECTOR RING SETTING	20	40	100	150
ACTUAL FLOW (L/MIN)	22	44	102	167
NOZZLE REACTION (KGF)	1	3	6	9

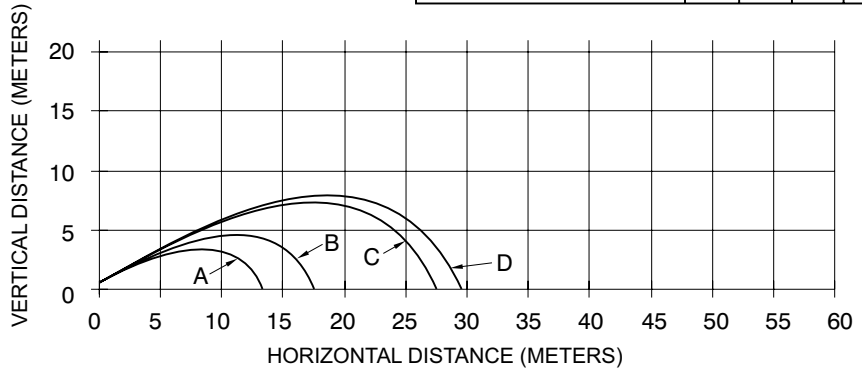

QUADRAFOG QF150 SERIES

Selectable flow nozzle with 4 flow settings of 20, 40, 100 and 150 GPM at 6 bar nozzle inlet pressure. DMR A 4/10

NOZZLE TESTED

Model: QF150
Serial #: KKD-140514

QF150 at 8 BAR

CURVE	A	B	C	D
SELECTOR RING SETTING	20	40	100	150
ACTUAL FLOW (L/MIN)	26	53	121	189
NOZZLE REACTION (KGF)	2	3	8	12

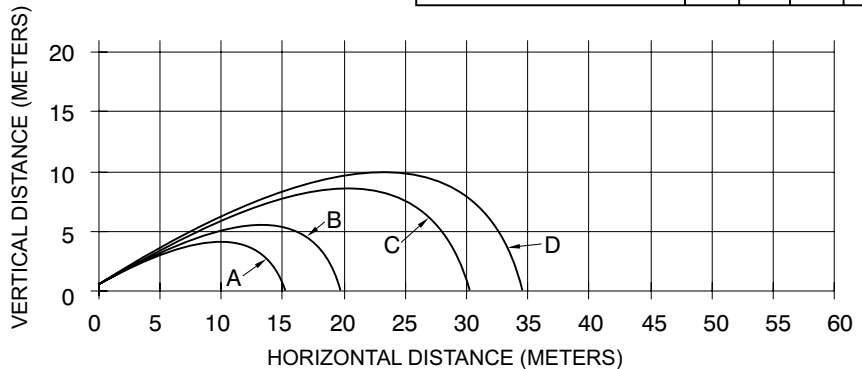

Notes: Stream trajectories shown are for no wind conditions at 30 degree elevation. Wind can substantially alter the shape and reach of the stream of any nozzle. Effective fire fighting range of nozzles is shown. Maximum range of last water drop is approximately 10% farther.

QUADRAFOG QF500 STREAM TRAJECTORIES

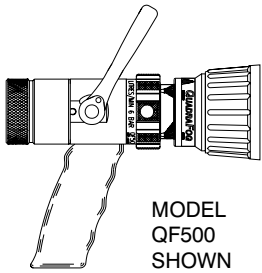

QF500 AT 4 BAR

CURVE	A	B	C	D
SELECTOR RING SETTING	100	250	360	475
ACTUAL FLOW (L/MIN)	91	216	295	379
NOZZLE REACTION (KGF)	4	10	14	17

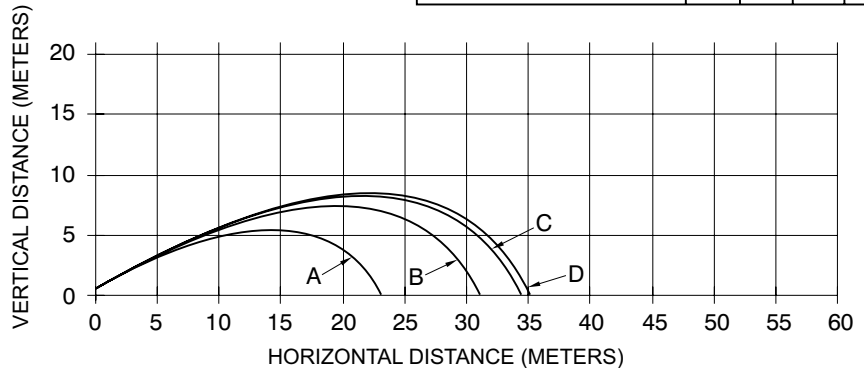

QF500 AT 6 BAR

CURVE	A	B	C	D
SELECTOR RING SETTING	100	250	360	475
ACTUAL FLOW (L/MIN)	110	265	360	475
NOZZLE REACTION (KGF)	6	15	20	27

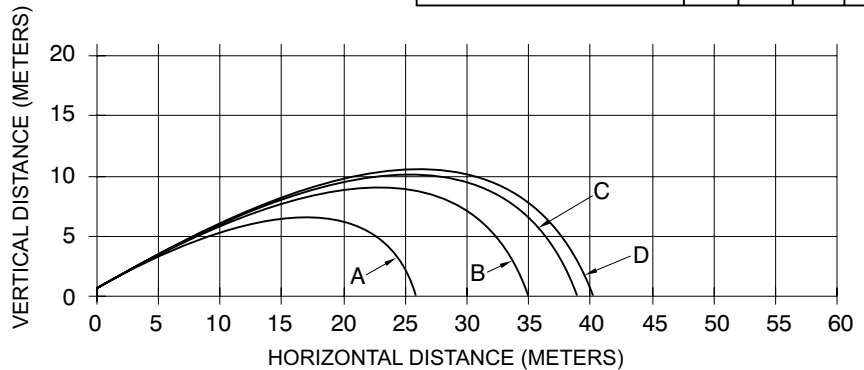

QUADRAFOG QF500 SERIES

Selectable flow nozzle with four flow settings of 100, 250, 360 and 475 l/min at 6 bar nozzle inlet pressure. DMR A 10/18

NOZZLE TESTED

Model: QF500
Serial #: KKF-147362

QF500 AT 8 BAR

CURVE	A	B	C	D
SELECTOR RING SETTING	100	250	360	475
ACTUAL FLOW (L/MIN)	129	307	416	553
NOZZLE REACTION (KGF)	8	20	27	36

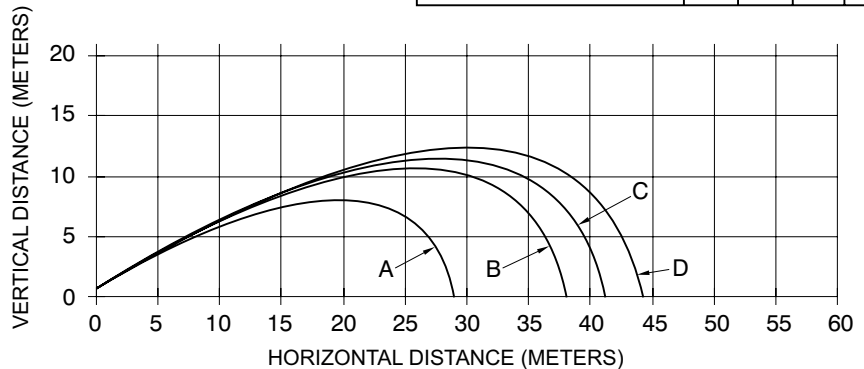

Notes: Stream trajectories shown are for no wind conditions at 30 degree elevation. Wind can substantially alter the shape and reach of the stream of any nozzle. Effective fire fighting range of nozzles is shown. Maximum range of last water drop is approximately 10% farther.

QUADRAFOG QF1000 STREAM TRAJECTORIES

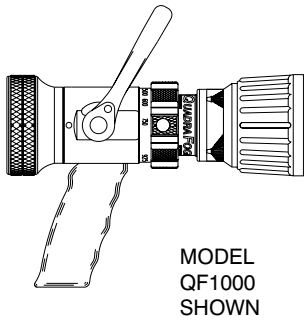

QF1000 AT 4 BAR

CURVE	A	B	C	D	E
SELECTOR RING SETTING	350	500	600	750	925
ACTUAL FLOW (L/MIN)	337	447	519	636	750
NOZZLE REACTION (KGF)	16	21	24	29	35

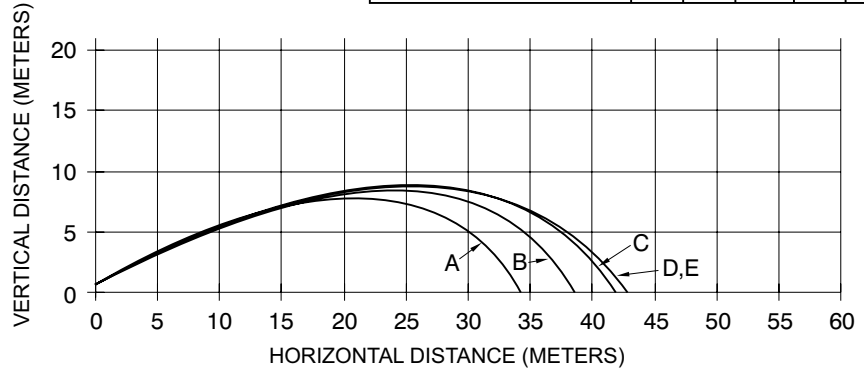

QUADRAFOG QF1000 SERIES
 Selectable flow nozzle with 5 flow settings of 350, 500, 600, 750, and 925 l/min at 6 bar nozzle inlet pressure. DMR A 18/25

NOZZLE TESTED

Model: QF1000
 Serial #: KKJ-155131

QF1000 AT 6 BAR

CURVE	A	B	C	D	E
SELECTOR RING SETTING	350	500	600	750	925
ACTUAL FLOW (L/MIN)	401	530	640	772	925
NOZZLE REACTION (KGF)	23	30	36	44	52

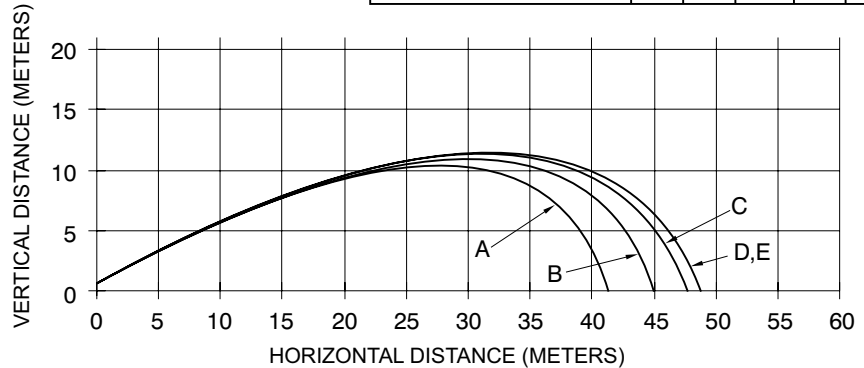

QF1000 AT 8 BAR

CURVE	A	B	C	D	E
SELECTOR RING SETTING	350	500	600	750	925
ACTUAL FLOW (L/MIN)	466	583	742	897	1056
NOZZLE REACTION (KGF)	30	38	48	58	69

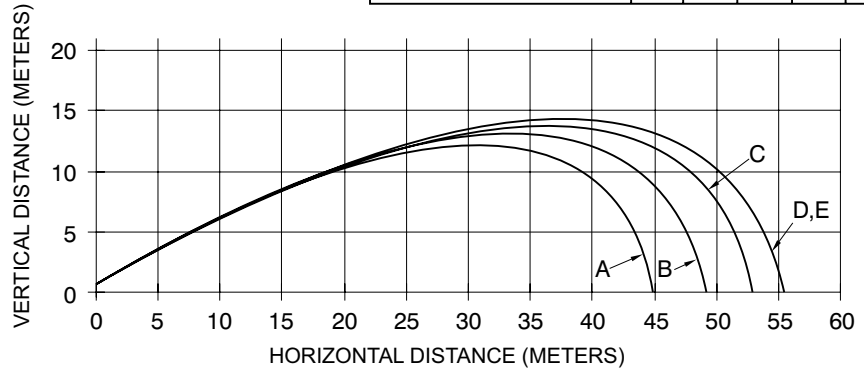

Notes: Stream trajectories shown are for no wind conditions at 30 degree elevation. Wind can substantially alter the shape and reach of the stream of any nozzle. Effective fire fighting range of nozzles is shown. Maximum range of last water drop is approximately 10% farther.

 **TASK FORCE TIPS**
2800 East Evans Avenue, Valparaiso, IN 46383
Tel: (219) 462-6161 Fax: (219) 464-0620

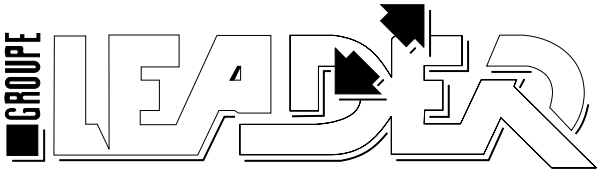
 **LEADER**
68, Bd. Jules Durand, 76600 LE HAVRE, FRANCE
Tel: (33) 35.53.05.75 Fax: (33) 35.53.16.32